

Taxonomy of perisphinctid ammonites of the Early Oxfordian (Late Jurassic) from near Herznach, Canton Aargau, Switzerland

by

REINHART A. GYGI^{*)}

With 14 plates, 25 figures and 22 tables in the text

Zusammenfassung

1336 Ammoniten des frühen Oxfordiums sind Schicht für Schicht in einer Flächengrabung auf dem Brunnrain bei Üken gesammelt worden, einem Dorf in der Nähe des heute geschlossenen Eisenbergwerks Herznach. Weitere Ammoniten stammen aus verstürzten Blöcken in den Stollen des Bergwerks Herznach. Die Perisphinctiden machen 42% der Ammonitenfauna aus. Ein beträchtlicher Teil von ihnen wird hier erstmals beschrieben. Eine neue Gattung und eine neue Untergattung werden vorgeschlagen, welche wahrscheinlich ein dimorphes Paar bilden. 8 neue formelle und zwei neue informelle Taxa der Artgruppe wurden erkannt. Die genauen Alter (Subchron) von früher beschriebenen Arten werden hier erstmals angegeben.

Schlüsselwörter: Ammoniten – Oxfordium – Jura – Schweiz.

Summary

1336 ammonites of Early Oxfordian age have been collected bed by bed from a systematic excavation on the Brunnrain near Üken, a village close to the now closed iron mine of Herznach. Some additional ammonites came from fallen blocks in the Herznach mine. The perisphinctids are 42% of the ammonite fauna, a considerable number of them being new. One new genus and a new subgenus are proposed which are probably a dimorphic pair. 8 new formal and two new informal taxa at the species level are presented. The exact ages (subchron) of some previously described species can now be indicated.

Key words: Ammonites – Oxfordian – Jurassic – Switzerland

Contents

1. Introduction	2	Subgenus <i>Eichinicerias</i> n. sg.	8
1.1 Previous work	2	<i>Tenuisphinctes</i> (<i>Eichinicerias</i>) <i>rolandi</i> n. sp.	8
1.2 Provenance of the material	2	Genus <i>Perisphinctes</i>	10
1.3 Age of the material	3	Subgenus <i>Kranaosphinctes</i>	10
2. Taxonomy	3	<i>Perisphinctes</i> (<i>Kranaosphinctes</i>) cf. <i>cyrilli</i>	10
2.1 Introductory remarks	3	<i>Perisphinctes</i> (<i>Kranaosphinctes</i> ?) <i>sylviae</i> n. sp.	11
2.1.1 Dimensions	3	Subgenus <i>Arisphinctes</i>	12
2.1.2 Maturity of specimens	4	<i>Perisphinctes</i> (<i>Arisphinctes</i>) <i>plicatilis</i>	12
2.1.3 The palaeontologic "species"	4	<i>Perisphinctes</i> (<i>Arisphinctes</i>) sp. gr. <i>plicatilis</i>	13
2.2 Systematic descriptions	5	<i>Perisphinctes</i> (<i>Arisphinctes</i>) <i>healeyi</i>	14
Genus <i>Tenuisphinctes</i> n. g.	5	<i>Perisphinctes</i> (<i>Arisphinctes</i>) <i>primigenius</i> n. sp.	16
Subgenus <i>Tenuisphinctes</i> n. sg.	5	<i>Perisphinctes</i> (<i>Arisphinctes</i>) <i>iodes</i> n. sp.	17
<i>Tenuisphinctes</i> (<i>Tenuisphinctes</i>) <i>kruegeri</i> n. sp.	5	<i>Perisphinctes</i> (<i>Arisphinctes</i>) <i>parvus</i> n. sp.	18

^{*)} Address of the author: Dr. R. GYGI, Naturhistorisches Museum, Augustinergasse 2, CH-4001 Basel, Switzerland.

<i>Perisphinctes (Arisphinctes) cf. parvus</i> n.sp.	20	<i>Perisphinctes (Otosphinctes) zbindeni</i> n.sp.	29
<i>Perisphinctes (Arisphinctes) sp. A</i>	21	Subgenus indeterminatum	31
<i>Perisphinctes (Arisphinctes) sp. B</i>	22	<i>Perisphinctes</i> (subgenus indet.) sp.	31
<i>Perisphinctes (Arisphinctes?) langei</i> n.sp.	23	Genus <i>Subdiscosphinctes</i>	32
Subgenus <i>Otosphinctes</i>	24	<i>Subdiscosphinctes (Subdiscosphinctes?)</i> sp.	32
<i>Perisphinctes (Otosphinctes) paturattensis</i>	24	3. Conclusions.	33
<i>Perisphinctes (Otosphinctes) episcopalensis</i>	26	Acknowledgements.	33
<i>Perisphinctes (Otosphinctes) gresslyi</i>	28	References	34
<i>Perisphinctes (Otosphinctes) cf. ouatius</i>	29	Explanation of plates	35

1. Introduction

1.1 Previous work

Perisphinctids of the Early Oxfordian *cordatum* Zone in northern Switzerland were first described by DE LORIOLE between 1896 and 1901. NEUMANN (1907) figured some Early Oxfordian ammonites from a quarry near a village that was then called Cetechowitz (somewhat less than 50 km east of Brno, Czechia) in an outlier (klippe) at the outer margin of the western Carpathians. Two of the taxa described and named by NEUMANN occur also near Herznach in the *cordatum* Subzone. JEANNET (1951) described the Early Oxfordian oppeliids and aspidoceratids of the Herznach iron mine but omitted the much commoner perisphinctids and cardioceratids. Two of the taxa figured by BOURSEAU (1977) from Beauvoisin, Département Drôme, southeastern France, have also been recorded in the *cordatum* Subzone of Herznach.

Some Early Oxfordian ammonites have also been described in the past from Poland (e.g. BUKOWSKI, 1887, MALINOWSKA, 1963, eastern France (e.g. MAIRE, 1932) and Britain (e.g. ARKELL, 1939, 1945 in ARKELL, 1935–48), but they are of slightly older age – *mariae* Zone or lowest *cordatum* Zone – or belong to groups not found at Herznach (e.g. *Prososphinctes* sp. *consociatus* (BUKOWSKI), or consist of nuclei too small to be closely identifiable. They will not be further considered here. The widespread occurrence of the *cordatum* Zone in northern Europe in the so-called *renggeri* clay facies, yielding ammonites mainly as small pyritized juveniles or nuclei, and the widespread absence of beds of this age further south, in the Submediterranean and Tethyan domains, has left a serious gap in our knowledge of the perisphinctids of this age. One of the few localities at which they are both relatively abundant and fully preserved as adults of both dimorphs is the region around Herznach, and it is the purpose of this article to go some way towards filling this gap. Our lack of knowledge of the European forms has been especially felt because perisphinctids are common in the *cordatum* Zone or its equivalents in the Indo-Madagascanian Province of the southern hemisphere, south of the Jurassic Neotethys (e.g. WAAGEN, 1875, SPATH, 1931: Dhosa Oolite of Kutch; COLLIGNON, 1959: Madagascar). There has been no basis for comparison with the classical successions of Europe.

1.2 Provenance of the material

The majority of the perisphinctids studied here were collected during a systematic, bed-by-bed excavation on the Brunnrain near Üken AG (Text-fig. 1). Üken is the neighbouring township north of Herznach, Canton Aargau (AG). The specimens from the Herznach iron mine were found in blocks fallen from the ceiling of the galleries and caverns. The ammonites from Üken and Herznach are from the Schellenbrücke Bed as defined by the author (GYGI, 1977, p. 454). This condensed bed is time-equivalent with the beds F 2 to F 3 of JEANNET (1951, fig. 2). Sections of the Schellenbrücke Bed in the Herznach iron mine and in the excavation near Üken have also been published (GYGI, 1977, pl. 11) as has a study of the complicated mode of formation of this bed (GYGI, 1981, fig. 3). Perisphinctids of the Glaukonitsandmergel Bed (ZEISS, 1955, fig. 30) from Siblingen and Gächlingen, Canton Schaffhausen (SH, Text-fig. 1) are included here, because their age is known exactly and could be used to date some of the material from near Herznach.

The perisphinctids figured in this paper are kept in the following institutions:

MNHB: Museum of Natural History Basel (individual numbers with prefix J)
 ETHZ: Federal Institute of Technology, Zürich, Geological Department



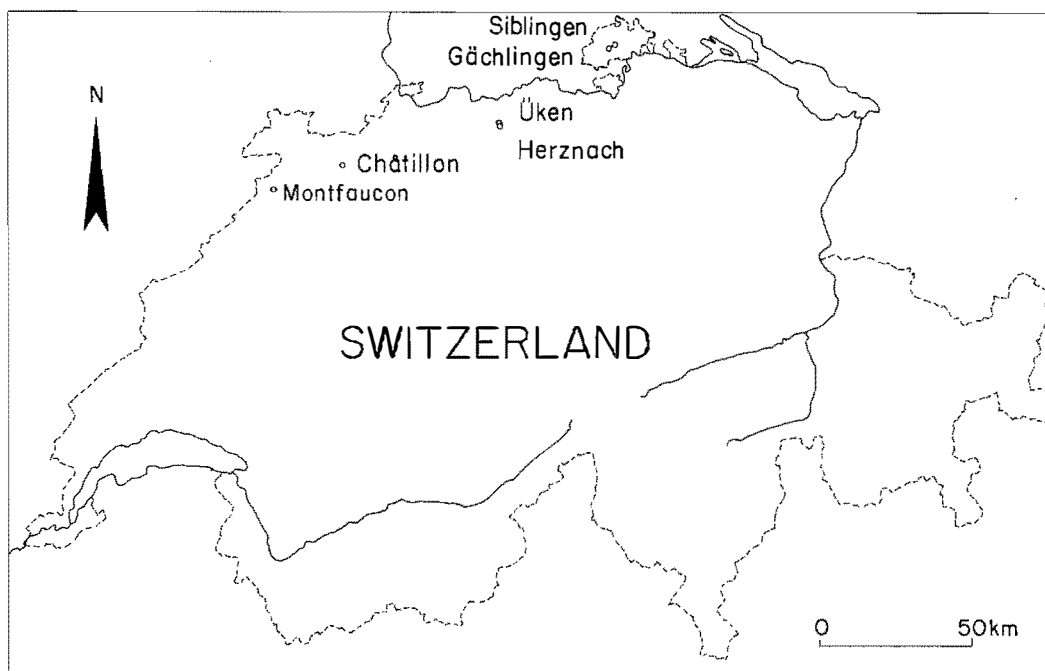

Text-fig. 1. Localities of the described perisphinctids and of some of their types.

The majority of the material was collected by R. and S. GYGI in 1971. This is supplemented by specimens collected by R. GYGI in 1962, B. PAGANINI in 1974 and Wissenschaftliche Arbeitsgemeinschaft Bergwerk Herznach (WABH) in 1976. Additional specimens were given to the MNHB by R. EICHIN and G. SCHMID. ETHZ (M. Pika-Biolzi) gave four specimens on loan.

1.3 Age of the material

The standard chronostratigraphy of the Early Oxfordian followed here is in summary:

	Zones	Subzones
Middle Oxfordian	<i>transversarium</i>	<i>densiplicatum</i>
Early Oxfordian	<i>cordatum</i>	<i>cordatum</i>
		<i>costicardia</i>
		<i>bukowskii</i>
	<i>mariae</i>	<i>praecordatum</i>
		<i>scarburgense</i>
Late Callovian		

GYGI & MARCHAND (1982) concluded from the cardioceratids in the Schellenbrücke Bed of Canton Aargau that it is a condensed bed which was deposited in the *scarburgense* and *cordatum* Subchrons (see GYGI & MARCHAND, 1982, pl. 3, figs. 1 and 2). The same authors dated the Glaukonitsandmergel Bed of Canton Schaffhausen at the *cordatum* Subchron of the Early Oxfordian. The exact age of the new perisphinctids from the Schellenbrücke Bed that do not occur also in the Glaukonitsandmergel Bed can therefore not be indicated until conspecific ammonites from in situ out of non-condensed sections elsewhere will be available.

2. Taxonomy

2.1 Introductory remarks

2.1.1 Dimensions

All the measured ammonites are iron oolitic internal moulds of ferruginous calcium carbonate. The dimensions of the specimens are measured according to fig. 16 in CECCA & ENAY (1991). The abbreviations in the dimensional tables are the following:

Dm	Diameter of the shell (in millimeters)	Ph	Diameter of the phragmocone
Wh	Whorl height	Nu	Nucleus (specimen wholly septate)
Wt	Whorl thickness	Ur	Umbilical ribs
Um	Width of umbilicus	n	Number of umbilical ribs

2.1.2 Maturity of specimens

Maturity (the adult stage) of specimens may be diagnosed through the following signs, if discernible: modifications of the final peristome, if preserved e.g. with the onset of lappets; approximation of the last septal sutures on the phragmocone; modification of the ribbing on the body-chamber (variocostation), e.g. through attenuation. The onset of the body-chamber is indicated on the plates by an arrow.

2.1.3 The palaeontological “species”

The species concept in ammonite palaeontology varied greatly with time. At an early stage, in the period of taking an inventory (that is by no means terminated), a common practice developed to describe any distinct morphologic type as a species. When the published material became more plentiful, some authors began to surmise that the number of genetic or biological ammonite species might be much less than the great number of described taxa at the “species” level, as for instance SPATH (1938, p. 25) or ARKELL (1948, p. 380). The genetic ammonite species would then have had a great variability. Indeed, CALLOMON (1963, p. 49) gave a convincing example of such a highly variable species, *Cranocephalites* from the Middle Jurassic of East Greenland. “This stretches from large, globose, smooth, involute shells to much smaller evolute, coarsely-ribbed planulates not unlike some Perisphinctids”. CALLOMON (1985, p. 55) concluded that all the *Cardioceratidae* at one given level were merely members of a single genetically linked assemblage, a biospecies.

The famous experiments by GAUSE (1934) seemed to substantiate this view. This Russian biologist worked with protozoan species of the genus *Paramecium*. Competition between two different species in a given glass tube ended with the complete extermination of one of the two species. When the experiment was repeated, always the same species disappeared. GAUSE’s conclusion was that no two species can live together indefinitely in the same ecological niche. This “exclusion principle” as cited from COLINVAUX (1978, p. 144) had a great influence on animal taxonomy both in neo- and palaeozoology. Of course, the relationship of protozoans and ammonites is too distant both genetically and temporally to draw an analogy, and how much do we really know about the ecology of ammonites? Nevertheless, the ammonite palaeontologist MARCHAND (1986), following CALLOMON (1985), recognized in the Oxfordian genus *Cardioceras* only one polymorphic species in a distinct time interval (subchron).

It cannot be decided whether MARCHAND’s conclusion is correct. MAYR (1964, p. 255) reported several examples of areally restricted biotopes that support many genetically separated species of the same genus. For instance, CRANE (1941) found 15 species of the Central American crab *Uca* on 50 m² of mud at the Pacific end of the Panama canal near Balboa. At other localities, he found up to 11 species of *Uca* that all require about the same environmental conditions. The mostly or entirely herbivorous fish of Bermuda in the subtropical West Atlantic are another example. At least 16 species of these fishes live on and between the reefs of Bermuda living off very similar algae (compiled by GYGI, 1975 and 1977, p. 460, from several authors). The taxonomic problem in palaeontology is further aggravated by the fact that sibling species of the Recent are very common in nature (MAYR, 1975, p. 169). These are genetically separated species that cannot be discerned by their external characters. Consequently, it is impossible to detect them in palaeontology.

A total of roughly 2500, mostly small perisphinctids is available for research from the Schellenbrücke Bed near Herznach. This bed is thin and the rate of sedimentation was mostly very low. Consequently, there was a strong bias towards the fossilization of small internal molds (steinkerns). Well-preserved large forms are rare. Perisphinctids have a pronounced dimorphism (CALLOMON, 1963, fig. 6). Recognition of biological species in the perisphinctids of the Schellenbrücke Bed is in most cases impossible, because macroconchs are rarely sufficiently preserved. The perisphinctid taxonomy in this bed must then remain tentative and provisional. For practical reasons, more and artificial taxa have to be named and described than have really existed because of the incomplete material.

CALLOMON (1963, p. 50) was of the opinion that names are necessary to describe morphologic differences between varying forms of a given fauna. Macroconchs [M] and microconchs [m], if recognizable, should be

grouped into parallel subgenera. BROCHWICZ-LEWINSKI (1975, p. 87) followed this practice, although he (1976, p. 115) pointed out that dimorphism in perisphinctids is not always easy to recognize. ZEISS (1969, p. 161) did not fully approve with the arrangement of dimorphic groups into separate subgenera, because he thought it might lead to a further inflation of names. He advocated the pragmatic practice (1969, p. 160) that the system of fossil animals should be an (artificial) classification that is as lucidly arranged as possible. GYGI (1977, p. 459) adopted this conservative, morphologic species concept, and it is also followed in the present paper, because the collections being described here are extensive enough only to justify an initial, morphospecific classification.

2.2 Systematic descriptions

Class Cephalopoda CUVIER, 1797

Order Ammonoidea ZITTEL, 1884

Superfamily Perisphinctaceae STEINMANN, 1890

Family Perisphinctidae STEINMANN, 1890

Subfamily Perisphinctinae STEINMANN, 1890

Genus *Tenuisphinctes* n. g.

Type species: *Tenuisphinctes (Tenuisphinctes) kruegeri* n. sp. [M].

Diagnosis: Macro- and microconchs of Oxfordian perisphinctids resembling Callovian *Choffatia* and Oxfordian *Platysphinctes*. The innermost whorls are densely ribbed. Then the ribs become progressively wider spaced and tend to fade away on the body chamber of macroconchs. The septal sutures are more complicated than in *Platysphinctes* TINTANT, 1961 (see this paper, fig. 3).

Temporal and geographical range: Early Oxfordian of northern Switzerland.

Subgenus *Tenuisphinctes* n. sg. [M]

Type species: *Tenuisphinctes (Tenuisphinctes) kruegeri* n. sp. [M].

Diagnosis: Macroconchs of *Tenuisphinctes* with a maximum diameter around 200 mm with a simple peristome.

Tenuisphinctes (Tenuisphinctes) kruegeri n. sp. [M]

Plate 1, Fig. 1, Text-figs. 2A, 3–4, Table 1

Holotype: Plate 1, fig. 1, MNHB J 27523.

Type locality: RG 251 in the iron mine, Herznach AG.

Type horizon: Schellenbrücke Bed, Early Oxfordian.

Derivation of the name: The name honours Mr. D. Krüger, D-Grenzach-Wyhlen, a private collector who has given important ammonites to the Museum of Natural History Basel.

Diagnosis: Macroconchs of *Tenuisphinctes* with a diameter in excess of 200 mm. Innermost whorls densely ribbed. The primary and the secondary ribs fade away almost entirely on the body chamber. Peristome simple.

Description: The diameter of the adult holotype at the peristome is 210 mm. This specimen is septate to the diameter of 125 mm, the final sutures not being approximated. The body chamber occupies almost the whole last whorl. The primary ribs begin at the umbilical suture. They bend 10° to 20° forward and are fine and sharp on the inner whorls. On the last half whorl of the phragmocone the primary ribs become low and blunt. They fade out almost completely on the body chamber and modify slightly near the peristome. The point of division into secondary ribs is diffuse. On the body chamber there are three secondary ribs per primary rib. The secondary ribs have the same direction as the primaries. They are attenuated along the siphonal line. The whorl-section is high-oval (Text-fig. 2A). The umbilical wall is well rounded. The rib-curve of the holotype descends between diameters of 40 mm and 140 mm, then becomes horizontal (Text-fig. 4). The rib-curve of the specimen ETHZ 464 rises from 44 ribs at diameter 20 mm to 56 ribs at 80 mm. This is at variance with the holotype. Nevertheless, the specimen may be regarded to be conspecific with the holotype.

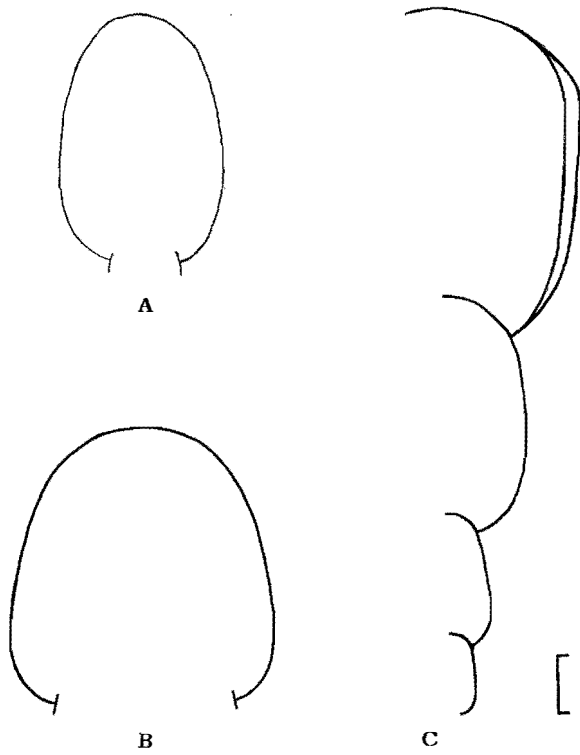

Text-fig. 2. Whorl sections of A: *Tenuisphinctes (Tenuisphinctes) kruegeri* n.sp. J 27523, B: *Perisphinctes (Arisphinctes) healeyi* NEUMANN J 30513 and C: *Perisphinctes (Arisphinctes)* sp. B J 27566. Bar is 1 cm.



Text-fig. 3. Septal suture line of *Tenuisphinctes (Tenuisphinctes) kruegeri* n.sp. ETHZ no. 464. Bar is 1 cm.

Ribs per whorl

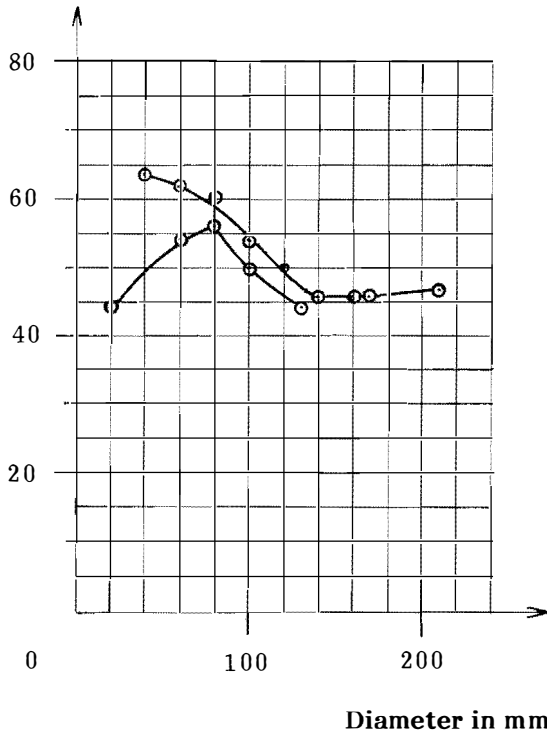

Text-fig. 4. Rib curves of *Tenuisphinctes (Tenuisphinctes) kruegeri* n.sp. J 27523 (large specimen) and ETHZ 464 (smaller specimen).

Table 1. Dimensions of *Tenuisphinctes (Tenuisphinctes) kruegeri* n.sp. [M].

Individual labelling of specimen	Ph mm	Dimensions, mm				in % of Dm			Ur/whorl	
		Dm	Wh	Wt	Um	Wh	Wt	Um	Dm	n
MNHB J 27523 Holotype	125	168	43	32	88	26	19	52	210	42
									160	41
									120	50
									80	60
									40	63
ETHZ 464	126	131	37	32	62	28	24	47	130	44
									100	50
									80	56
									60	54
									20	44

Affinities: *Tenuisphinctes (Tenuisphinctes) kruegeri* [M] resembles Callovian *Choffatia* in the type of ribbing, the whorl section and in the relatively strong dissection of the septal suture line (see MANGOLD, 1970). There is some resemblance in the Oxfordian between *Tenuisphinctes* and *Platysphinctes* TINTANT, 1961. *Platysphinctes* is somewhat smaller with a maximum diameter of the phragmocone of only 80 to 100 mm. The ribbing is similar, but the septal suture line of *Platysphinctes* is simpler than in *Tenuisphinctes*.

Material: 2 specimens: MNHB J 27523 and ETHZ 464.

Stratigraphical unit: Schellenbrücke Bed.

Age: The exact age is uncertain, but probably *cordatum* Subchron. GYGI & MARCHAND (1982) found that the ammonites in the Schellenbrücke Bed were partly from the *scarburgense* Subchron (few specimens) and partly from the *cordatum* Subchron (the great majority).

Tenuisphinctes (Tenuisphinctes) sp.

Plate 13, Fig. 1, Text-fig. 5, Table 2

Description: The iron oolitic, carbonate internal mould of MNHB J 32297 is a wholly septate nucleus. The whorl section is elliptic and compressed. The umbilical ribs begin above a narrow, smooth band above the umbilical suture line. The primary ribs of the last whorl are low and blunt. They form a slightly proconcave arc

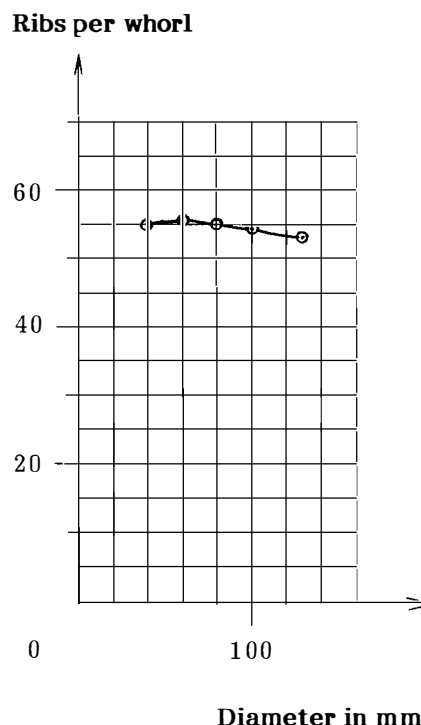

Text-fig. 5. Rib curve of *Tenuisphinctes (Tenuisphinctes) sp.* J 32297.

Diameter in mm

Table 2. Dimensions of *Tenuisphinctes* (*Tenuisphinctes*) sp. [M].

Individual labelling of specimen	Ph num	Dimensions, mm				in % of Dm			Ur/whorl	
		Dm	Wh	Wt	Um	Wh	Wt	Um	Dm	n
MNHB J 32297	Nu	130	38	30	63	29	23	49	130	53
									100	54
									80	55
									60	56
									40	55

which has a radial string. The point of division into secondary ribs is at two thirds of the whorl height. There are sometimes two, but predominantly three weak and blunt secondary ribs per primary rib. The secondary ribs have the same direction as the primaries. They are not attenuated along the siphonal line. The last whorl covers the preceding one by one third of the whorl height.

Affinities: The specimen J 32297 from Herznach resembles the type of *Tenuisphinctes* (*Tenuisphinctes*) *gyrus* NEUMANN in the whorl section and in the flat rib curve. It differs from the type in that the primary ribs are arcuate and that their string is radial. The primary ribs of *gyrus* are stronger and less numerous than in the specimen from Herznach, and *gyrus* is more evolute. *Perisphinctes ubligi* NEUMANN resembles *Tenuisphinctes* (*T.*) sp. in the ribbing, but it has another whorl section.

Material: 1 specimen: MNHB J 32297.

Stratigraphical unit: Schellenbrücke Bed.

Age: The minimum age is the *cordatum* Subchron.

Subgenus *Eichinicerias* n.sg. [m]

Type species: *Tenuisphinctes* (*Eichinicerias*) *rolandi* n.sp. [m].

Diagnosis: Microconchs of *Tenuisphinctes* whose maximum diameter of the phragmocone is 95 mm, larger than the phragmocones of *Alligaticeras* and *Properisphinctes* or *Otosphinctes*. The rib-curve first rises, then descends as in macroconchs. This is the main difference from younger *Dichotomosphinctes*.

Tenuisphinctes (*Eichinicerias*) *rolandi* n.sp. [m]

Plate 9, Fig. 3, Plate 11, Fig. 4, Plate 12, Fig. 4, Text-fig. 6, Table 3

Holotype: Plate 11, Fig. 4, MNHB J 22652.

Type locality: Iron mine, Herznach AG.

Type horizon: Schellenbrücke Bed, Early Oxfordian.

Derivation of the name: The name honours Mr. Roland Himmler, Oberwil BL, a private collector who has given an important collection of Oxfordian ammonites to the Museum of Natural History Basel.

Diagnosis: Microconchs of *Tenuisphinctes* with a maximum diameter estimated at 125 mm (no complete specimens are available). The whorl section is high-oval and the ribbing faint. The septal suture line closely resembles the one of *Tenuisphinctes* s.str. The form is smaller and more involute and compressed than *Dichotomosphinctes*, but larger than *Alligaticeras*, *Properisphinctes* or *Otosphinctes*.

Description: The incomplete holotype has a maximum diameter of 82 mm and is septate to the diameter of 71 mm (Table 3). One third of the last whorl is occupied by the body chamber. The compressed whorl section is high-oval. The umbilical wall is low and well-rounded. The primary ribs are fine and densely spaced on the inner whorls. From the diameter of 40 mm their distance increases. On the body chamber the primaries are faint and blunt. The primary ribs bend 15° to 20° forward. The point of division into secondary ribs is diffuse. There are two to three faint secondary ribs per primary. The secondaries are attenuated along a narrow siphonal band. They have the same direction as the primary ribs. The rib curve of the holotype rises from 50 ribs at the diameter of 20 mm to 54 ribs at the diameter of 40 mm, then falls (Text-fig. 6). There are three to four constrictions per whorl.

Affinities: *Tenuisphinctes* (*Eichinicerias*) *rolandi* n.sp. resembles *Tenuisphinctes* (*Tenuisphinctes*) *kruegeri* n.sp. in the whorl section and in the ribbing so much that there can be no doubt that it is the microconch of

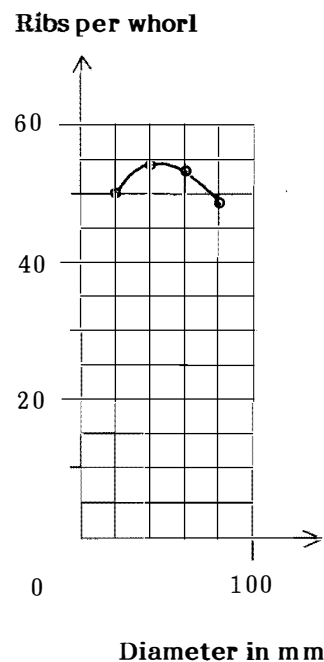

Text-fig. 6. Rib curve of *Tenuisphinctes (Eichinicerias) rolandi* n.sp. J 22652, holotype.

Tenuisphinctes (Tenuisphinctes) kruegeri n.sp. The diameter of full-grown phragmocones is about 80 mm in *Tenuisphinctes (Eichinicerias) rolandi* and 125 mm in *Tenuisphinctes (Tenuisphinctes) kruegeri*. Full-grown *Tenuisphinctes* s.str. have probably one more whorl than *Eichinicerias*. There is some resemblance between *Eichinicerias* n.sg. and *Prososphinctes* SCHINDEWOLF, 1925 (type species: *Perisphinctes mazuricus* BUKOWSKI). The umbilicus of *Prososphinctes* is narrower, the ribbing is finer and the forward inclination of the primary ribs of *Prososphinctes* is stronger than in *Eichinicerias*.

Material: 5 specimens: MNHB J 22652, J 27464, J 23431, J 23339, J 23343.

Stratigraphical unit: Schellenbrücke Bed.

Age: The minimum age is the *cordatum* Subchron.

Table 3. Dimensions of *Tenuisphinctes (Eichinicerias) rolandi* n.sp. [m].

Individual labelling of specimen	Ph mm	Dimensions, mm				in % of Dm			Ur/whorl	
		Dm	Wh	Wt	Um	Wh	Wt	Um	Dm	n
MNHB J 22652 Holotype	71	67	21	15	29	31	22	43	80	48
									60	53
									40	54
									20	50
MNHB J 27464	Nu	75	26	21	29	35	28	39	80	53
									60	51
									40	49
									20	43
MNHB J 23431	Nu	70	24	-	28	34	-	40	80	40
									60	46
									40	55
									20	50
MNHB J 23339	46	61	22	-	38	36	-	38	60	45
									40	45
									20	41
MNHB J 23343	Nu	58	21	-	22	36	-	38	70	45
									60	50
									40	54
									20	42

Genus *Perisphinctes* WAAGEN, 1869
 Subgenus *Kranaosphinctes* BUCKMAN, 1921 [M]

Type species: *Kranaosphinctes kranaus* BUCKMAN, 1921 [M]

Perisphinctes (Kranaosphinctes) aff. cyrilli NEUMANN, 1907 [M]

Plate 10, Fig. 1, Plate 13, Fig. 4, Text-fig. 7, Table 4

Description: The iron oolitic, carbonate internal mould of the specimen MNHBJ 27520 is wholly septate. The whorl section is almost circular, slightly depressed. The primary ribs begin above a narrow, smooth band on the steep umbilical wall. On the whorl sides they are straight and strong and bend 8° to 15° forward. At 80% of the whorl height the primary ribs split up into two weak and blunt secondaries. The secondary ribs have the same direction as the primaries. The constrictions are deep. The last whorl covers the preceding one by 16%.

Affinities: The dimensions of the described specimen J 27520 from Herznach are very similar to the holotype of *Perisphinctes cyrilli* NEUMANN, 1907, pl. 4, fig. 12. The primary ribs of J 27520 are slightly projected, whereas the primaries of the holotype of *cyrilli* are radial. The whorl section of the holotype is subcircular, but the sides of the last whorl are somewhat flattened. This corresponds with J 27520 from Herznach. The last whorl of the holotype covers the preceding one by 18% as compared with 16% in J 27520. The difference in the rib curve is very marked: The curve of the holotype can be measured from the diameter of 70 mm where there are 42 primary ribs. The curve reaches a maximum of 56 ribs at the diameter of 130 mm and then slowly descends. In J 27520 the curve begins at the diameter of 20 mm with 44 ribs and reaches the maximum of 55 ribs already at the diameter of 60 mm. Then the curve becomes more or less horizontal. This is the reason why J 27520 and the holotype of *Perisphinctes (Kranaosphinctes) cyrilli* NEUMANN cannot be conspecific.

The rib-curve of ETHZ 304 from Herznach resembles the curve of J 27520. These two specimens are similar. Another similar specimen from Herznach is J 32358, but it is deformed and might be conspecific with *Perisphinctes (Kranaosphinctes) methodii* NEUMANN. *Perisphinctes (Kranaosphinctes) cyrilli* NEUMANN is the closest in Europe of a group common in the Early Oxfordian of the Indo-Madagascanian Province: *P. rota* WAAGEN (1875, pl. 48, fig. 1), *P. kheraensis* SPATH (1931, pl. 74, fig. 5), *P. jacobi* (COLLIGNON) (1959, pl. 41, fig. 213): evolute, almost isocostate, and largely biplicate even on the outer whorls.

Ribs per whorl

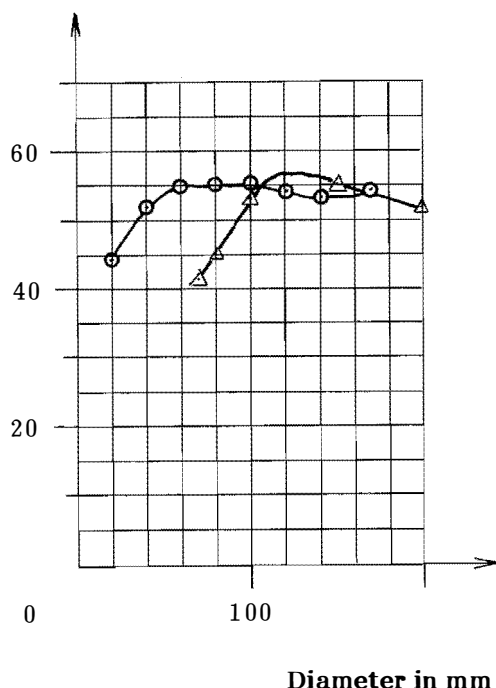

Text-fig. 7. Rib curves of *Perisphinctes (Kranaosphinctes) aff. cyrilli* J 27520 (circles) and holotype of *Perisphinctes (Kranaosphinctes) cyrilli* NEUMANN (triangles) as measured at the type.

Table 4. Dimensions of *Perisphinctes (Kranaosphinctes) aff. cyrilli* NEUMANN [M].

Individual labelling of specimen	Ph mm	Dimensions, mm				in % of Dm			Ur/whorl	
		Dm	Wh	Wt	Um	Wh	Wt	Um	Dm	n
MNHB J 27520	Nu	171	38	40	101	22	23	59	170	54
									140	53
									100	55
									60	55
									40	52
									20	44
ETHZ 304	Nu	97	26	30	51	27	31	53	95	48
									80	49
									60	50
									40	49
									20	38
									10	32

Material: 3 specimens MNHB J 27520, J 32358, ETHZ 304.

Stratigraphical unit: Schellenbrücke Bed.

Age: The age of the specimens described here is unknown. Their minimum age is the *cordatum* Subchron of the *cordatum* Chron. ENAY (1966, p. 435), MALINOWSKA (1972, p. 238) and MELENDEZ (1989, p. 221) stated that *Perisphinctes (Kranaosphinctes) cyrilli* NEUMANN occurred in the *antecedens* and *parandievi* Subchrons of the *transversarium* Chron.

Perisphinctes (Kranaosphinctes?) sylviae n.sp. [M]

Plate 11, Fig. 1, Plate 12, Fig. 1, Text-fig. 8, Table 5

Holotype: Plate 11, Fig. 1, MNHB J 23233.

Type locality: Excavation RG 208 on Brunnrain, Üken AG.

Type horizon: Schellenbrücke Bed, beds 8–9 of the excavation RG 208. The specimen has been taken in a part of the excavation where beds 8 and 9 could not be separated.

Derivation of the name: The name honours Sylvia Gygi who participated in the excavations and prepared the majority of the excavated ammonites.

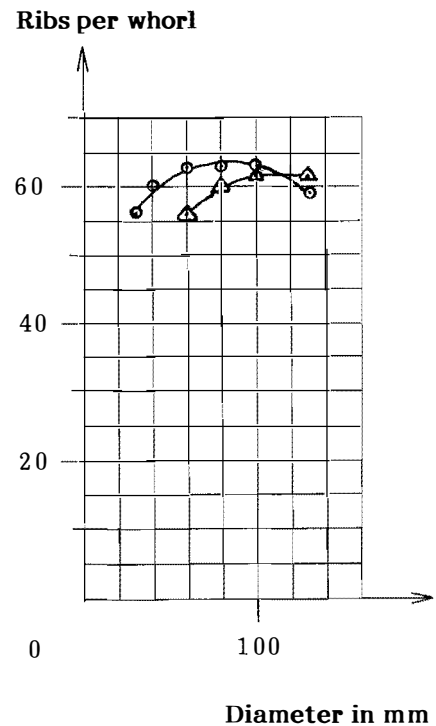

Text-fig. 8. Rib curve of *Perisphinctes (Kranaosphinctes?) sylviae* n.sp. J 23233, holotype (circles) and J 23230 (triangles).

Table 5. Dimensions of *Perisphinctes (Kranaosphinctes?) sylviae* n.sp. [M].

Individual labelling of specimen	Ph mm	Dimensions, mm				in % of Dm			Ur/whorl	
		Dm	Wh	Wt	Um	Wh	Wt	Um	Dm	n
MNHB J 23230	Nu	131	32	29	72	24	22	55	130	62
									100	62
									80	60
									60	57
MNHB J 23233	101	119	32	37	62	26	31	52	130	59
									100	63
									80	63
									60	63
									40	60

Diagnosis: Macroconch probably of *Kranaosphinctes* with a maximum diameter of more than 180 mm. The whorl section is subcircular and the umbilicus is more than 50% of the diameter.

Description: The iron oolitic, carbonate internal mould of the holotype is septate to the diameter of 101 mm. The body-chamber occupies half of the last whorl. The paratype J 23230 is wholly septate at the diameter of 130 mm. The whorl section is elliptic and depressed. At the end of the last whorl the sides become somewhat flattened and convergent. The primary ribs begin at the umbilical suture line. They are strong, sharp and slightly proconcave. The primary ribs lean a little backward on the umbilical wall, then 2° to 4° forward on the whorl sides. The point of division into secondary ribs is at 80% of the whorl height. There are two to three secondary ribs per primary rib on the last whorl. The secondary ribs have the same direction as the primaries. The secondary ribs are relatively strong and cross the siphonal side uninterrupted. The last whorl covers the preceding one by 20%.

Affinities: *Perisphinctes (Kranaosphinctes?) sylviae* n.sp. resembles *Perisphinctes (Kranaosphinctes)* aff. *cyrilli* in the whorl section. But it differs in the ribbing from *P. (K.)* aff. *cyrilli*: the ribs of *P. (K.?) sylviae* n.sp. are finer and more numerous. The primary ribs in *P. (K.?) sylviae* begin at the umbilical suture line. There is no smooth band at the base of the umbilical wall like in *P. (K.)* aff. *cyrilli*. The umbilicus of *P. (K.)* aff. *cyrilli* is considerably wider than in *P. (K.?) sylviae* n.sp.

Material: 2 specimens MNHB J 23230, J 23233.
Stratigraphical unit: Schellenbrücke Bed.
Age: The minimum age is the *cordatum* Chron.

Subgenus *Arisphinctes* BUCKMAN, 1924 [M]

Type species: *Arisphinctes ariprepes* BUCKMAN 1924-24 [M].

Perisphinctes (Arisphinctes) plicatilis (SOWERBY, 1817) [M]

Plate 14, Fig. 4, Text-fig. 9, Table 6

1989 *Perisphinctes (Arisphinctes) plicatilis* – MELENDEZ, p. 229, pl. 23, fig. 2?, non fig. 1, with synonymy

Table 6. Dimensions of *Perisphinctes (Arisphinctes) plicatilis* (SOWERBY) [M].

Individual labelling of specimen	Ph mm	Dimensions, mm				in % of Dm			Ur/whorl	
		Dm	Wh	Wt	Um	Wh	Wt	Um	Dm	n
MNHB J 23412	Nu	109	33	-	48	31	-	44	130	70
									100	70
									80	69
									60	60?
MNHB J 23222	Nu	94	34	-	38	36	-	38	94	70
									80	69
									60	65
									40	57
									20	47

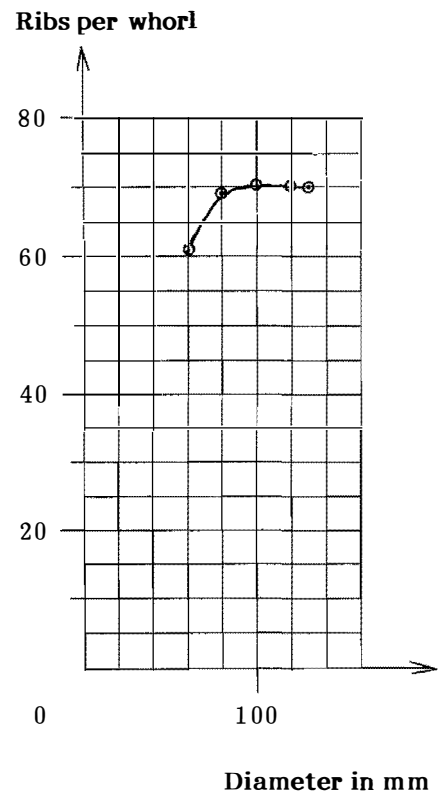

Text-fig. 9. Rib curve of *Perisphinctes (Arisphinctes) plicatilis* (SOWERBY) J 23412.

Description: The internal mould of MNHB J 23222 is a wholly septate nucleus. The primary ribs begin on the rounded umbilical margin and swing somewhat back on this margin. The fine primaries are straight and radial on the slightly convex whorl sides. The point of division into secondary ribs is at 70 % of the whorl height. There are two secondaries per primary rib. The fine secondary ribs have either the same radial direction as the primaries or they bend slightly forward. They are not attenuated at the siphonal side which is rounded. The last whorl covers the preceding one by 33 %.

Affinities: The dimensions, the whorl section and the rib curve of J 23222 are very close to the holotype of *P. (A.) plicatilis* as figured by ARKELL (1939, pl. 29, fig. 1). The only difference is in the slight forward bending of some of the secondary ribs in J 23222.

Material: 2 specimens: MNHB J 23222, J 23412.

Stratigraphical unit: Schellenbrücke Bed.

Age: The described form is morphologically so close to the type from the English *plicatilis* Chron that it is most probable that it is the direct precursor from the *cordatum* Subchron.

Perisphinctes (Arisphinctes) sp. gr. plicatilis (SOWERBY, 1817) [M]

Plate 2, Fig. 4, Text-fig. 10, Table 7

Description: The iron oolitic, carbonate internal mould of MNHB J 32298 is a wholly septate nucleus. The primary ribs begin on the inner whorls at the umbilical suture line. On the last whorl they begin higher up on the rounded umbilical wall. The ribs are straight, fine and sharp. They bend 11° forward. The point of division into secondary ribs is at 80 % of the whorl height. There are two to three secondary ribs per primary. The secondaries have the same direction as the primary ribs. They are not attenuated at the siphonal side where the shell is preserved. The whorl sides are slightly convex and the siphonal side is rounded. The last whorl covers the preceding one by 33 %.

Affinities: The umbilicus of the specimen from Herznach is somewhat wider than that of the holotype of *P. (A.) plicatilis*. The principal difference is in the rib-curve (Text-fig. 10). The ribbing of the Herznach specimen is denser than that of the holotype on the inner whorls and wider spaced on the last whorl.

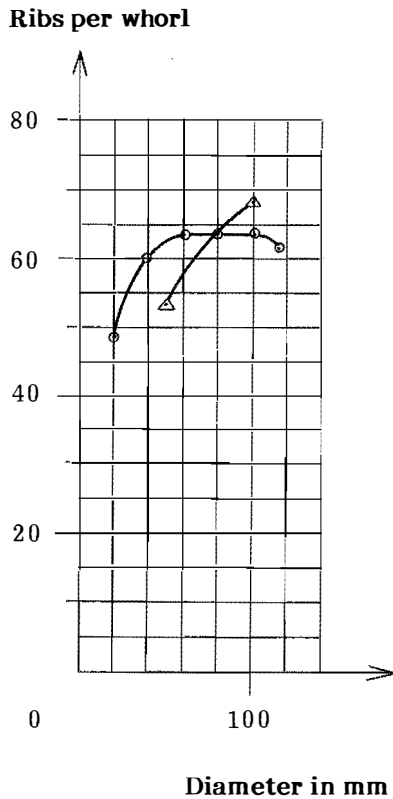

Text-fig. 10. Rib curves of *Perisphinctes (Arisphinctes)* sp. gr. *plicatilis* (SOWERBY) J 32298 (circles) and holotype of *plicatilis* (triangles).

Table 7. Dimensions of *Perisphinctes (Arisphinctes)* sp. gr. *plicatilis* (SOWERBY) [M].

Individual labelling of specimen	Ph mm	Dimensions, mm				in % of Dm			Ur/whorl	
		Dm	Wh	Wt	Um	Wh	Wt	Um	Dm	n
MNHB J 32298	Nu	112	32	29	54	29	26	48	115	62
									100	68
									80	68
									60	68
									40	60
									20	48

Material: MNHB J 32298.
 Stratigraphical unit: Schellenbrücke Bed.
 Age: Probably *cordatum* Subchron.

Perisphinctes (Arisphinctes) healeyi NEUMANN, 1907 [M]

Plate 3, Fig. 1, Text-figs. 2B, 11, Table 8

v 1907 *Perisphinctes Healeyi* - NEUMANN, p. 29, pl. 2, fig. 5

Lectotype (designated here): Original to pl. 2, fig. 5 in NEUMANN (1907), University of Vienna, Dept. of Palaeontology.
 Type locality: quarry near Cetechowitz, Czechia.
 Type horizon: red-grey nodular limestone, "Cordatusschichten".

Description: The ferruginous, carbonate internal mould of the specimen MNHB J 30513 is septate to the diameter of 204 mm. A quarter of the last whorl is body-chamber. The last two septal sutures are approximated. The specimen must therefore be adult. The diameter of the complete shell was at least 250 mm. The whorl-section is thick-oval (Text-fig. 2B) with a rounded siphonal side. The primary ribs begin above the smooth and steep umbilical wall. They bend slightly backward on the umbilical margin. The primaries are straight and strong on the whorl sides where they bend forward. The point of division into secondary ribs is very high on the whorl sides: it is at 85% of the whorl height. The secondary ribs on the last whorl of the phragmocone are low and blunt. They

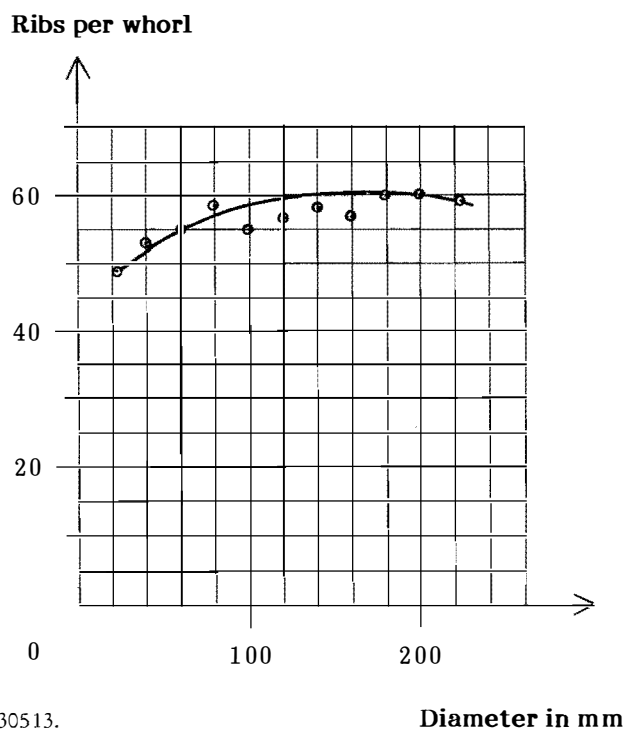

Text-fig. 11. Rib curve of *Perisphinctes (Arisphinctes) healeyi* NEUMANN J 30513.

Table 8. Dimensions of *Perisphinctes (Arisphinctes) healeyi* NEUMANN [M].

Individual labelling of specimen	Ph mm	Dimensions, mm				in % of Dm			Ur/whorl	
		Dm	Wh	Wt	Um	Wh	Wt	Um	Dm	n
Univ. Vienna Holotype	80?	140	37	-	76	26	-	54	140	59
									100	57
MNHB J 30513	204	211	48	48	120	23	23	57	220	59
									160	57
									100	55
									40	53
MNHB J 27519	Nu	176	44	44	94	25	25	53	170	52
									140	54
									100	55
									60	48
MNHB J 32295	Nu	169	39	37	93	23	22	55	170	61
									140	63
									100	59
									50	51
MNHB J 24719	145	163	44	42	85	27	26	52	160	53
									140	54
									100	50
									60	46
MNHB J 27531	144	141	42	35	62	30	25	44	140	57
									100	58
									60	59

fade away just before the end of the phragmocone. There are two to three secondaries per primary rib. The secondaries have the same direction as the primaries. The last whorl covers the preceding one by only 12%.

Affinities: The dimensions, the whorl section and the style of ribbing of *Perisphinctes healeyi* NEUMANN are so close to *Arisphinctes* of the *densiplicatum* Subchron (for the zonal scheme adopted here: see GYGI, in the press, and this paper, p. 3) that it is very probable that NEUMANN's taxon is an *Arisphinctes* immediately preceding the forms of the early *transversarium* Chron and the English *plicatilis* Chron. The lectotype is much smaller than the material from Herznach and is probably a juvenile.

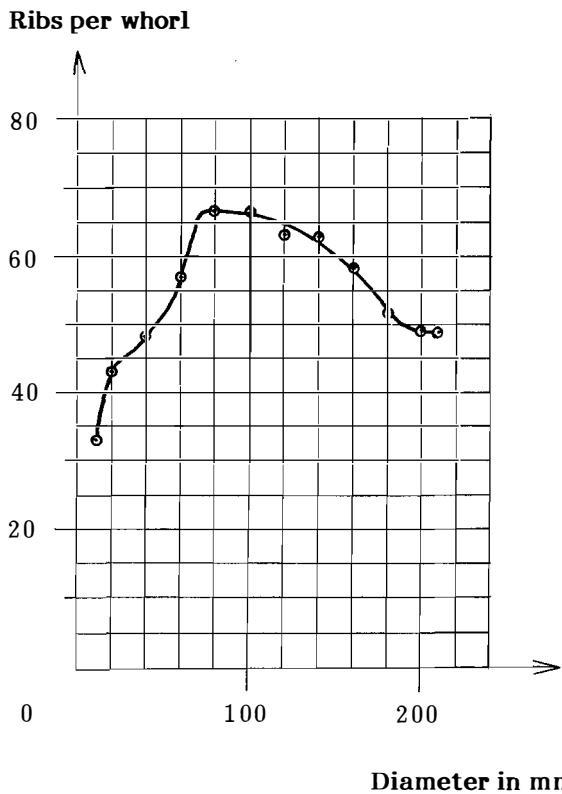

Text-fig. 12. Rib curve of *Perisphinctes (Arisphinctes) primigenius* n.sp. J 23232.

Material: 5 specimens: MNHB J 30513, J 27519, J 32295, J 24719, J 27531.
Stratigraphical unit: Schellenbrücke Bed.
Age: Probably *cordatum* Subchron.

Perisphinctes (Arisphinctes) primigenius n. sp. [M]

Plate 4, Fig. 1, Text-fig. 12, Table 9

Holotype: Pl. 4, fig. 1, MNHB J 23232.
Type locality: Excavation RG 208 on Brunnrain, Üken AG.
Type horizon: Schellenbrücke Bed, n.o. 9 of the excavation.
Derivation of the name: from the Latin word for original.

Diagnosis: Macroconch of *Arisphinctes* with a diameter greater than 200 mm. The whorl section is oval and the umbilicus is very wide.

Description: The iron oolitic, carbonate internal mould of the holotype is septate to the diameter of 170 mm. The body chamber occupies almost the whole last whorl. The last three ribs are approximated, indicating that the specimen is adult. The primary ribs begin on the inner whorls at the umbilical suture line. On the last whorl the umbilical wall is smooth, and the primaries begin only at the umbilical margin. The primary ribs are straight, strong and sharp. They lean 20° forward on the inner whorls and 10° on the last whorl. The point of division into weak, blunt secondary ribs is at 78% of the whorl height. There are two to three secondaries per primary rib on the body chamber. The secondary ribs have the same direction as the primaries. They fade away before the aperture where the siphonal side becomes smooth. The whorl section is oval. The umbilicus is very wide (Table 9).

Affinities: The small size of this new taxon with respect to the giant *Arisphinctes* of the English *plicatilis* Zone is regarded to be an ancestral character. The umbilicus is wider than that of later *Arisphinctes* at comparable growth stages. In this respect it resembles *Dichotomosphinctes (Otosphinctes) jacobi* COLLIGNON from the early Oxfordian of Madagascar. But the ribbing of the inner whorls is much denser in the new taxon from Üken.

Material: 1 specimen: MNHB J 23232.

Table 9. Dimensions of *Perisphinctes (Arisphinctes) primigenius* n. sp. [M].

Individual labelling of specimen	Ph mm	Dimensions, mm				in % of Dm			Ur/whorl	
		Dm	Wh	Wt	Um	Wh	Wt	Um	Dm	n
MNHB J 23232	170	209	47	43	121	23	21	58	200	49
									160	58
									100	67
									60	57
									40	48
									10	33

Stratigraphical unit: Schellenbrücke Bed.
Age: The minimum age is the *cordatum* Subchron.

Perisphinctes (Arisphinctes) iodes n. sp. [M]

Plate 5, Fig. 1, Text-fig. 13, Table 10

Holotype: Plate 5, Fig. 1, MNHB J 23414.
Type locality: RG 209 in the iron mine, Herznach AG.
Type horizon: Schellenbrücke Bed.

Derivation of the name: From the Greek word ωδησ = rusty. The name refers to the rusty-brown colour of the fossils from the Schellenbrücke Bed.

Diagnosis: Macroconch of *Arisphinctes* with a diameter greater than 250 mm. The somewhat convex whorl sides converge only slightly and the curvature of the siphonal side has a greater radius than half the whorl height. The whorl section is thus subquadratic and resembles younger *Perisphinctes* s. str.

Description: The iron oolitic, carbonate internal mould of the holotype is septate to the diameter of 197 mm. One fifth of a whorl of body chamber is preserved. The primary ribs begin on the inner whorls partly at the umbilical suture line and partly on the steep umbilical wall. They swing back on the rounded umbilical margin. On the slightly convex whorl sides the primary ribs are straight, strong and sharp. The ribs lean 4–8° forward. The point of division into secondary ribs is at 72 % of the whorl height. There are two secondaries per

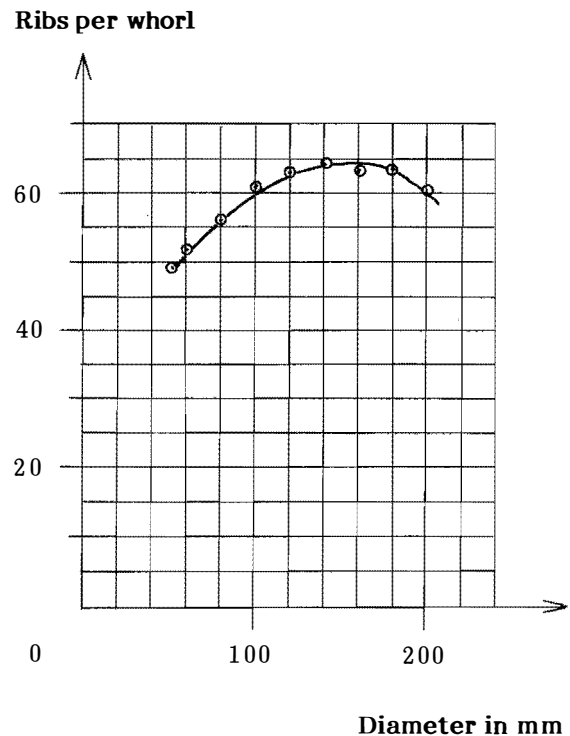

Text-fig. 13. Rib curve of *Perisphinctes (Arisphinctes) iodes* n. sp. J 23414.

Diameter in mm

Table 10. Dimensions of *Perisphinctes (Arisphinctes) iodes* n.sp. [M].

Individual labelling of specimen	Ph mm	Dimensions, mm				in % of Dm			Ur/whorl	
		Dm	Wh	Wt	Um	Wh	Wt	Um	Dm	n
MNHB J 23414	197	187	50	48	92	27	26	49	200	60
									180	63
									140	64
									100	61
									80	56
50	49									

primary rib on the phragmocone. One primary rib is undivided on the last whorl of the phragmocone. On the body chamber there are two to three secondaries per primary rib. The secondary ribs bend slightly forward and form a proconvex arc on the siphonal side. They are not attenuated along the siphonal line. The whorl section is subquadratic.

Affinities: The whorl section of *Perisphinctes (Arisphinctes) iodes* n.sp. is different from all other *Arisphinctes* in the Schellenbrücke Bed. The new taxon resembles in this respect *Perisphinctes* s.str. However, it is unlikely that this taxon is a direct precursor of *Perisphinctes* s.str. because no comparable forms have been found so far in the *densiplicatum* Subzone above. The first *Perisphinctes* s.str. occur only in the upper *antecedens* Subzone.

Material: 1 specimen: MNHB J 23414.

Stratigraphical unit: Schellenbrücke Bed.

Age: The minimum age is the *cordatum* Subchron.

Perisphinctes (Arisphinctes) parvus n.sp. [M]

Plate 8, Fig. 5, Plate 9, Fig. 1, Plate 11, Fig. 5, Text-fig. 14, Table 11

Holotype: Original to Plate 8, Fig. 5, MNHB J 24869.

Type locality: Excavation RG 212 above the shooting range in Churz Tal, Siblingen SH.

Type horizon: Glaukonitsandmergel Bed, no. 5 of the excavation..

Ribs per whorl

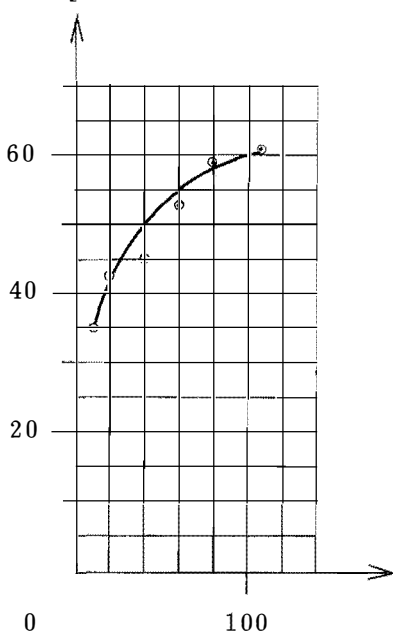

Diameter in mm

Text-fig. 14. Rib curve of *Perisphinctes (Arisphinctes) parvus* n.sp. J 24869, holotype.

Derivation of the name: The specimens of this taxon are septate to the diameter of 60 to 120 mm and are therefore much smaller than typical *Arisphinctes* of the English *plicatilis* Zone.

Diagnosis: Macroconchs of *Perisphinctes* (*Arisphinctes*) whose pragmomonocone has a diameter of less than 120 mm.

Description: The glauconitic, carbonate internal mould of the holotype is septate to the diameter of 104 mm. Only one eighth of a whorl of the body chamber is preserved. The umbilical wall is steep and smooth. The primary ribs begin on the rounded umbilical margin. They are straight and bend 5–10° forward. The point of division into secondary ribs is at 75% of the whorl height. The weak secondary ribs are only visible where the shell is preserved. They have the same direction as the primaries and are not attenuated at the siphonal side. There are two to three secondaries per primary rib. The whorl sides are only slightly convex, and the siphonal side is rounded.

Affinities: The whorl section and the ribbing are very similar to *Perisphinctes* (*Arisphinctes*) *plicatilis* (SOWERBY). From the diameter of 60 mm the rib curve of *P. (A.) parvus* rises somewhat less steeply than in *P. (A.) plicatilis*. The main difference between the two taxa is the size which is much less in *P. (A.) parvus* than in *Arisphinctes* of the English *plicatilis* Zone. The maximum diameter of full-grown *P. (A.) parvus* was, to judge

Table 11. Dimensions of *Perisphinctes* (*Arisphinctes*) *parvus* n. sp. [M].

Individual labelling of specimen	Ph mm	Dimensions, mm				in % of Dm			Ur/whorl	
		Dm	Wh	Wt	Um	Wh	Wt	Um	Dm	n
MNHB J 24869 Holotype	104	89	28	-	40	32	-	45	110	61
									80	59
									60	53
									40	45
									20	42
									10	35
MNHB J 23249	120	108	33	32	49	30	30	45	120	60
									100	59
									80	59
									60	57
									40	48
									20	39
MNHB J 23231	120?	118	35	-	56	30	-	49	120	57
									100	56
									80	56
									60	53
MNHB J 23416	100	117	33	27	54	28	23	46	120	48
									100	48
									80	47
									60	44
									40	38
MNHB J 23434	Nu	109	32	29	51	30	26	47	110	55
									100	55
									80	52
									60	51
									40	47
									20	42
10	35									
MNHB J 23313	98	91	30	-	38	33	-	42	100	52
									80	49
									60	45
									40	44
MNHB J 23454	88	90	30	-	38	33	-	42	100	62
									80	62
									60	61
									40	55
									20	52
									10	39
ETHZ, without nr	60	103	29	26	52	28	25	50	103	53
									80	50
									60	46
									40	42
									20	34

from specimen J 23231, about 160 mm. This suggests the possibility that *P. (A.) parvus* could be a microconch related to the younger *Dichotomosphinctes*. This is improbable, because the last ribs on the body chamber of the specimen J 23231 (Table 11) have a markedly greater distance than the primary ribs on the last whorl of the phragmocone. This indicates that the rib curve descends on the body chamber, and that the taxon is consequently macroconch.

Material: 9 specimens: MNHB J 24869 (holotype), J 23231, J 23249, J 23257, J 23313, J 23416, J 23434, J 23454 and ETHZ without number.

Stratigraphical units: Schellenbrücke Bed and Glaukonitsandmergel Bed (the holotype).

Age: The holotype is from the Glaukonitsandmergel Bed at Siblingen SH. This marker bed of Canton Schaffhausen has been dated with cardioceratids as *cordatum* Subchron by GYGI & MARCHAND (1982) and FISCHER & GYGI (1989).

Perisphinctes (Arisphinctes) cf. parvus n.sp.

Plate 14, Figs. 1, 5, Text-fig. 15, Table 12

Description: The iron oolitic, carbonate internal mould of the specimen MNHB J 23255 is septate to the diameter of ca. 78 mm. About one fifth of the last whorl is occupied by the body chamber. The whorl section is trapezoidal with a rounded siphonal side. The whorl sides are flat and somewhat convergent. The primary ribs begin above a narrow smooth band at the base of the umbilical wall. They bend backward on the umbilical margin. The primaries are straight on the whorl sides and bend 10° forward. The point of division into two secondary ribs is at 82% of the whorl height. The low and blunt secondaries run uninterrupted across the siphonal line. They have the same direction as the primary ribs. The last whorl covers the preceding one by about one third the whorl height.

The second specimen MNHB J 23453 is septate to the diameter of 109 mm. Only the beginning of the body chamber is preserved. The point of division of the primary ribs is lower than in the specimen J 23255: it is at 77% of the whorl height. The other characters and the rib curves are similar.

Affinities: The size and the other characters of the specimens MNHB J 23255 and J 23453 are very similar to *Perisphinctes (Arisphinctes) parvus* n.sp. But the ribbing on the innermost whorls of these two specimens is considerably denser than in *P. (A.) parvus*. A similar form is *Perisphinctes rollieri* DE LORIOLO

Ribs per whorl

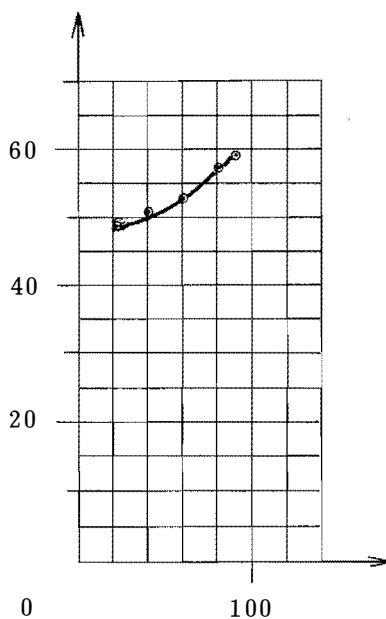

Diameter in mm Text-fig. 15. Rib curve of *Perisphinctes (Arisphinctes) cf. parvus* n.sp. J 23255.

Table 12. Dimensions of *Perisphinctes (Arisphinctes) cf. parvus* n.sp. [M].

Individual labelling of specimen	Ph num	Dimensions, mm				in % of Dm			Ur/whorl	
		Dm	Wh	Wt	Um	Wh	Wt	Um	Dm	n
MNHB J 23453	109	95	33	-	37	35	-	39	109	59
									80	57
MNHB J 23255	78	74	25	-	30	34	-	40	88	59
									60	53
									40	51
									20	49

(1901, p. 32, pl. 3, fig. 3). No septal sutures are visible on this ETHZ specimen that has a constriction at the end of the last whorl and might therefore be adult. It would then be a considerably smaller taxon than *Perisphinctes (Arisphinctes) parvus* n.sp.

Material: 2 specimens, MNHB J 23255 and J 23453.

Stratigraphical unit: Schellenbrücke Bed.

Age: The minimum age is the *cordatum* Subchron.

Perisphinctes (Arisphinctes) sp. A [M]

Plate 6, Fig. 1, Text-fig. 16, Table 13

Description: The iron oolitic, carbonate internal mould is septate to the diameter of 204 mm. Less than one fourth of the last whorl is occupied by the body chamber. The steep umbilical wall is smooth. The primary ribs begin on the umbilical margin. They are straight and strong. Most of them are radial. Some of them lean forward, at most 5°. They split up into 2-3 strong secondary ribs at 72% of the whorl height. The secondaries have the same direction as the primary ribs. They run over the siphonal side without being attenuated. ● on the body chamber the secondary ribs are only visible where the shell is preserved. There, the internal mould is smooth at the siphonal side. The whorl section is oval. The umbilicus is comparatively narrow.

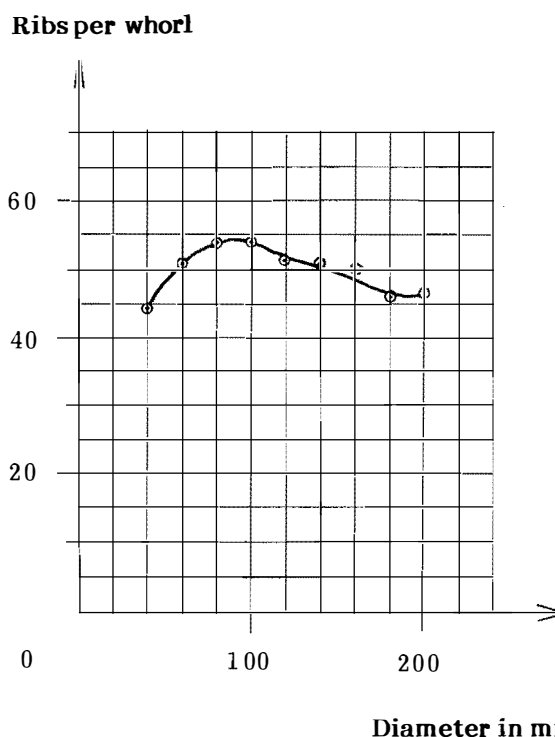

Text-fig. 16. Rib curve of *Perisphinctes (Arisphinctes) sp. A* J 23457.

Diameter in mm

Table 13. Dimensions of *Perisphinctes (Arisphinctes)* sp. A [M].

Individual labelling of specimen	Ph mm	Dimensions, mm				in % of Dm			Ur/whorl	
		Dm	Wh	Wt	Um	Wh	Wt	Um	Dm	n
MNHB J 23457	204	177	51	-	86	29	-	48	200	47
									160	50
									120	52
									100	54
									80	54
									60	51
									40	44

Affinities: This informal taxon resembles *Perisphinctes (Arisphinctes) healeyi* NEUMANN, but the umbilicus is narrower than in NEUMANN's form, and the ribbing is somewhat looser (compare Text-fig. 11 with 16).

Material: 1 specimen: MNHB J 23457.

Stratigraphical unit: Schellenbrücke Bed.

Age: The minimum age is the *cordatum* Subchron.

Perisphinctes (Arisphinctes) sp. B [M]

Plate 7, Fig. 1, Text-fig. 17, Table 14

Description: The iron oolitic, carbonate internal mould is wholly septate. The phragmocone had a minimum diameter of about 250 mm. The section of the inner whorls is trapezoidal with a convex siphonal side as is normal in *Arisphinctes*. The fragment of the last whorl has an inversely trapezoidal section (Text-fig. 2C) with a low and inclined umbilical wall. The siphonal side of the last whorl is broadly arched. The primary ribs begin at the umbilical suture line. They are straight and sharp on the inner whorls. On the fragment of the last whorl they are proconcave. The forward inclination of the primary ribs is 8° to 12° on the inner whorls and increases on the fragment of the last whorl. On this whorl fragment the umbilical ribs form low nodes at the distal end of the ribs on the siphonal margin. The point of division into secondary ribs is at about 70% of the whorl height. The primary ribs split into two to three secondary ribs that have the same direction as the

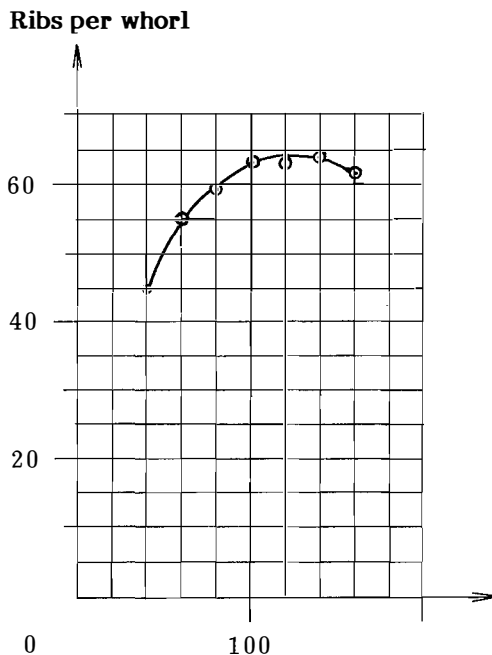

Diameter in mm Text-fig. 17. Rib curve of *Perisphinctes (Arisphinctes)* sp. B J 27566.

Table 14. Dimensions of *Perisphinctes (Arisphinctes)* sp. B [M].

Individual labelling of specimen	Ph mm	Dimensions, mm				in % of Dm			Ur/whorl	
		Dm	Wh	Wt	Um	Wh	Wt	Um	Dm	n
MNHB J 27566	Nu	159	43	-	78	27	-	49	160	62
		140							140	64
		100							100	63
		80							80	59
		60							60	55
		40							40	45

primaries. On the last whorl fragment the siphonal side is smooth. The fragment of the last whorl covers the preceding whorl by 20%.

Affinities: *Perisphinctes (Arisphinctes)* sp. B resembles *Arisphinctes* of the *plicatilis* group in the ribbing and in the section of the inner whorls. It differs from *Perisphinctes (Arisphinctes) plicatilis* (SOWERBY) and *Perisphinctes (Arisphinctes) healeyi* NEUMANN in the section of the fragment of the last whorl.

Material: 1 specimen MNHB J 27566.

Stratigraphical unit: Schellenbrücke Bed judging from the material of the internal mould.

Age: The minimum age is the *cordatum* Subchron.

Perisphinctes (Arisphinctes?) langei n.sp.

Plate 12, Fig. 5, Plate 13, Fig. 5, Text-fig. 18, Table 15

Holotype: Original to Plate 13, Fig. 5, MNHB J 24642.

Type locality: Excavation RG 81b below Räckolterenbuck, Gächlingen SH.

Type horizon: Glaukonitsandmergel Bed, no. 11 of the excavation.

Derivation of the name: The name is in honour of Burkhard Lange, Basel, a private collector who gave important specimens to the Museum of Natural History Basel.

Ribs per whorl

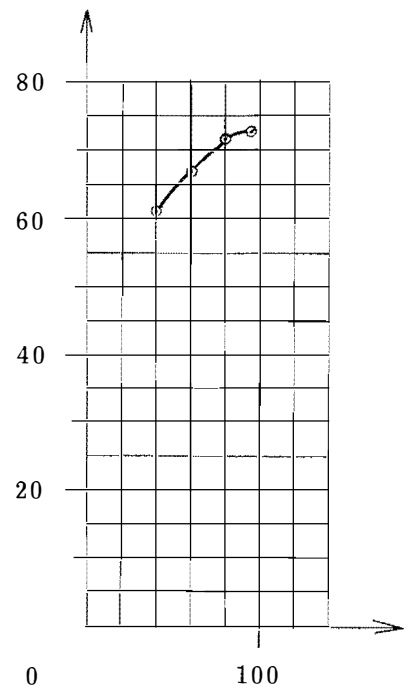

Text-fig. 18. Rib curve of *Perisphinctes (Arisphinctes?) langei* n.sp. J 24642, holotype.

Diameter in mm

Table 15. Dimensions of *Perisphinctes (Arisphinctes?) langei* n. sp.

Individual labelling of specimen	Ph mm	Dimensions, mm				in % of Dm			Ur/whorl	
		Dm	Wh	Wt	Um	Wh	Wt	Um	Dm	n
MNHB J 23251	113	91	34	-	33	37	-	37	110 80 60	80 78 71
MNHB J 24642 Holotype	Nu	93	32	28	37	35	30	40	96 80 60 40	73 72 67 61
MNHB J 23246	Nu	75	25	22	31	33	29	42	80 60 40 20	71 67 55 44

Diagnosis: Taxon with a maximum diameter of at least 170 mm. The umbilicus is narrower and the number of primary ribs per whorl is greater than in typical *Arisphinctes*.

Description: The glauconitic, carbonate internal mould of the holotype is wholly septate. The iron oolitic, carbonate internal mould of specimen MNHB J 23251 is septate to the diameter of 113 mm and has a small portion of the body chamber. The whorl section is trapezoidal with a rounded siphonal side. The umbilical wall is smooth. The primary ribs begin on the umbilical margin and there bend backward. On the whorl sides the primary ribs are straight and weak. There they bend 6°–11° forward. The point of division into secondary ribs is at 75 % of the whorl height. There are as a rule two secondary ribs per primary, but in the holotype five primary ribs are unsplit. The secondary ribs bend somewhat more forward than the primaries and form a proconvex arc on the siphonal side. In the holotype the secondary ribs are attenuated along the siphonal line. The last whorl covers the preceding one by one third.

Affinities: The size of this taxon is similar to *Perisphinctes (Arisphinctes) parvus* n. sp. The umbilicus is however narrower than in *P. (A.) parvus* and the ribbing is denser (compare Text-fig. 14 with Text-fig. 18). *Perisphinctes (Arisphinctes?) langei* n. sp. resembles microconchs of *Subdiscosphinctes* of the later *transversarium* Chron. There is some similarity to *Prososphinctes*, but the primary ribs of *Prososphinctes* have a stronger forward inclination.

Material: 4 specimens, MNHB J 23223, J 23246, J 23251 and J 24642.

Stratigraphical units: Glaukonitsandmergel Bed and Schellenbrücke Bed.

Age: *cordatum* Subchron of the *cordatum* Chron.

Subgenus *Otosphinctes* BUCKMAN, 1926 [m]

Type species: *Otosphinctes ouatius* BUCKMAN, 1926 [m].

Perisphinctes (Otosphinctes) paturattensis DE LORIO, 1901 [m]

Plate 8, Figs. 2, 3, Plate 10, Fig. 3, Plate 11, Fig. 3, Plate 12, Figs. 2, 3, Plate 13, Figs. 2, 3, Text-fig. 19, Table 16

1901 *Perisphinctes paturattensis* – DE LORIO, p. 23, pl. 2, figs. 2–6

1989 *Perisphinctes (Otosphinctes) paturattensis* – MELENDEZ, p. 270, Text-fig. 52, pl. 36, figs. 2–7, with synonymy

Lectotype: Original to Plate 2, Fig. 4 in DE LORIO (1901), designated by ENAY (1966, p. 447).

Type locality: Former clay pit in the depression at point 998 east of the farm La Pâturatte (coordinates 572'500/233'100) at Montfaucon JU (Swiss National Map, sheet 1105, Bellelay).

Type horizon: "Oxfordien moyen" in terms of DE LORIO, this is to say Terrain à Chailles Member of the Bärschwil Formation.

Remark: The description and figurations by DE LORIO (1901, p. 23, pl. 2, figs. 2–6) and the description, discussion and figurations by ENAY (1966, p. 447, figs. 123–3 to 9, 133, pl. 25, fig. 3) are so accurate and complete that there is no need for another description in this paper. Only one point should be noted: The rib curve of specimen J 23353 is variocostate (see Fig. 19).

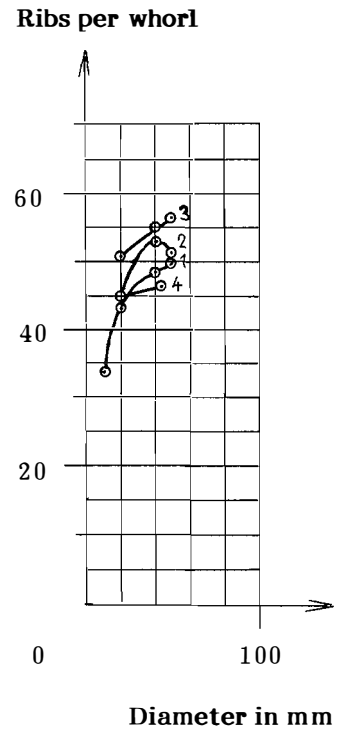

Text-fig. 19. Rib curves of *Perisphinctes (Otosphinctes) paturattensis* DE LORIO. 1: J 23422. 2: J 23353. 3: J 23290. 4: J 27420.

Table 16. Dimensions of *Perisphinctes (Otosphinctes) paturattensis* DE LORIO [m].

Individual labelling of specimen	Ph mm	Dimensions, mm				in % of Dm			Ur/whorl	
		Dm	Wh	Wt	Um	Wh	Wt	Um	Dm	n
MNHB J 23422	30	50.3	15.4	-	25.0	31	-	50	50	50
									40	48
									20	43
									10	34
MNHB J 23353	28	49.6	15.0	15.6	23.3	30	31	47	50	52
									40	53
									20	45
MNHB J 23290	30	47.7	16.8	14.2	21.2	35	30	44	48	57
									40	55
									20	51
MNHB J 23399	29	47.2	15.3	14.5	22.0	32	31	47	47	49
									40	48
									20	47
									10	41
MNHB J 23317	28	46.2	14.0	15.6	22.0	30	34	48	46	44
									40	42
									20	40
MNHB J 23197	?	44.5	14.5	14.0	20.0	33	31	45	45	45
MNHB J 27420	28	44.1	14.0	14.3	20.5	32	32	46	44	47
									20	45
MNHB J 23224	27.5	40	12	13	19	30	33	48	40	49
									20	51
									10	41

Material: 28 measured and more unmeasured specimens.

Stratigraphical units: Schellenbrücke Bed and Terrain à Chailles Member.

Age: The material of the internal mould of the lectotype at the ETH Zürich indicates that the type is from the Terrain à Chailles Member of the Bärschwil Formation. The age of the Terrain à Chailles Member ranges according to GYGI & PERSOZ (1986, tab. 2) from the *cordatum* Subchron to the *antecedens* Subchron. *Perisphinctes (Otosphinctes) paturattensis* DE LORIOI does not occur in the *renggeri* Member below the Terrain à Chailles Member, so it cannot be older than the *cordatum* Subchron. The lectotype of *P. (O.) paturattensis* was found in the distal facies realm of the Terrain à Chailles Member where most of the fossils occur in a decimeter-thick marl with carbonate concretions which is about in the middle of the Terrain à Chailles Member. GYGI & PERSOZ (1986, tab. 2) called this simply “Fossil bed”. Details about the age of this unnamed bed were given by GYGI & MARCHAND (1993): it is the *Cardioceras cordatum* Subchron. In the excavation RG 208 on Brunrain at Üken near Herznach AG, about 40 specimens of *P. (O.) paturattensis* were found in the Schellenbrücke Bed in an excavated area of 120 m². Some of these specimens are figured here. They are of the *Cardioceras cordatum* Subchron.

Only four specimens of *P. (O.) paturattensis* have been found in the Mumienmergel Bed north of Schaffhausen in the following excavations*:

RG 80	Siblingen, Schlossranden	2 m ² of excavated area
RG 81 a	Gächlingen, Räckolterenbuck	0.5
RG 81 b*	Gächlingen, Räckolterenbuck	43.5
RG 82	Siblingen, water conduit	0.5
RG 88	Blumberg, Stoberg	2
RG 207*	Siblingen, water conduit	12
RG 212	Siblingen, shooting range	16
RG 278	Blumberg, Stoberg	1
Total of excavated area:		77.5 m ²

The age of the thin, condensed Mumienmergel Bed is the *Cardioceras densiplicatum* Subchron and the early part of the *Perisphinctes antecedens* Subchron (GYGI, in the press, fig. 40). The vertical range of *P. (O.) paturattensis* in the type region of northern Switzerland is then mostly in the *C. cordatum* Subzone of the Early Oxfordian and just overlaps into the lowermost *C. densiplicatum* Subzone of the Middle Oxfordian.

Perisphinctes (Otosphinctes) episcopalis DE LORIOI, 1901 [m]

Plate 2, Figs. 1–2, Plate 7, Figs. 2–3, Plate 14, Fig. 3, Text-fig. 20, Table 17

1901 *Perisphinctes episcopalis* – DE LORIOI, p. 30, pl. 1, figs. 14–15

non 1930 *Perisphinctes episcopalis* – DORN, p. 163, pl. 12, fig. 5, pl. 14, fig. 5

1977 *Perisphinctes* (? *Dichotomosphinctes*) nov. sp. ? aff. *episcopalis* – BOURSEAU, p. 61, pl. 2, figs. 1–3

Lectotype: DE LORIOI’s syntypes could not be found, neither at the ETH Zürich nor at the Museum of Natural History Geneva. Therefore, the figure 15 in pl. 1 by DE LORIOI (1901) is designated here as lectotype, because it is the better preserved specimen. This specimen, too, appears to be lost. This figure is however very clear and readily identifiable. As no topotypes closely resembling the lectotype figure are at the moment available, it is best to defer the selection of a neotype.

Type locality: Clay pit of La Pâturatte, Montfaucon JU.

Type horizon: “Oxfordien moyen” in terms of DE LORIOI (1901, p. 31), this is to say Terrain à Chailles Member.

Description of the largest specimen J 27530 (Plate 7, Fig. 3): The iron oolitic, carbonate internal mould is septate to the diameter of 27 mm. The body chamber occupies somewhat more than three fourths of the last whorl. It is complete to the last constriction before the peristome. The peristome itself is broken off. The whorl section is oval. The primary ribs begin at the umbilical suture line. They swing backward on the umbilical wall. The primary ribs are straight and sharp on the whorl sides. There they lean 14° forward. The point of division into secondary ribs is at more than 75 % of the whorl height at the beginning of the body chamber where there are two secondaries per primary rib. At later ontogenetic stages the point of division comes down and is at about 60 % of the whorl height at the end of the body chamber. At this stage the point of division is diffuse and there are three secondaries per primary rib. The secondary ribs have the same direction as the primaries. On the first third of the body chamber some secondary ribs form parabolic nodes. There the secondary ribs are interrupted along a shallow siphonal furrow that fades away at later stages of the body chamber. The last two septal suture lines are strongly approximated. The specimen is then a nearly complete adult. At the inner whorls there are four constrictions per whorl. The rib curve typically rises from 42–43 ribs per whorl at a diameter of 10 mm to a maximum of 43–48 ribs per whorl at a diameter of 20 mm and then descends again (Text-fig. 20). The ribbing of this taxon is therefore variocostate, unlike other *Otosphinctes*.

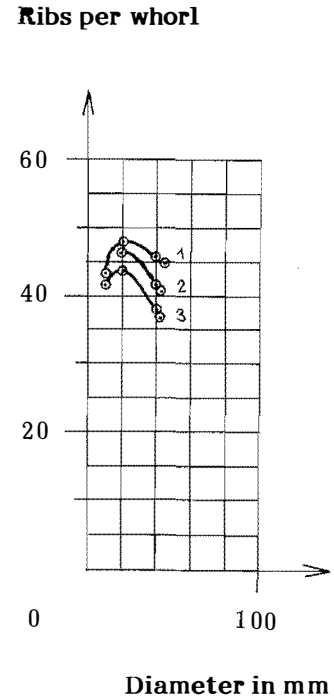

Text-fig. 20. Rib curves of *Perisphinctes (Otosphinctes) episcopalis* DE LORIO. 1: J 27530. 2: J 23468. 3: J 23287.

Table 17. Dimensions of *Perisphinctes (Otosphinctes) episcopalis* DE LORIO [m].

Individual labelling of specimen	Ph mm	Dimensions, mm				in % of Dm			Ur/whorl	
		Dm	Wh	Wt	Um	Wh	Wt	Um	Dm	n
MNHB J 27530	27	45.4	13.0	11.8	22.0	29	26	48	45	45
									40	46
									20	48
									10	43
MNHB J 23468	26.5	45.3	13.7	11.5	20.5	30	25	45	45	41
									40	42
									20	47
MNHB J 23287	27	43.4	13.0	11.0	20.8	30	25	48	43	37
									40	38
									20	44
									10	42
MNHB J 23328	23	37.4	11.4	9.5	17.1	30	25	46	37	43
									20	48
MNHB J 23275	24	33.9	10.6	10.0	16.5	31	29	49	37	39
									20	45
									10	38

Affinities: The specimens figured in this paper agree well with the lectotype in DE LORIO (1901, pl. 1, fig. 15). The syntype of pl. 1, fig. 14 in DE LORIO (1901) is larger than any of the measured specimens from Herznach and Üken. The figured specimens from Canton Aargau are all adult, therefore the lectotype is probably adult too as DE LORIO (1901, p. 31) presumed.

The varicosate rib curve and the trifurcate ribs are evidence that the taxon has a special position in *Otosphinctes*. ENAY (1966, p. 500) assigned two similar forms with reservation to *Dichotomosphinctes*. The size of the adults as figured here from Canton Aargau rather suggests that these specimens are *Otosphinctes*. DE LORIO (1901, p. 31) hinted that they might be microconchs of *Perisphinctes promiscuus* BUKOWSKI that is probably a *Kranaosphinctes* (GYGI, 1995, p. 31).

Material: 20 measured and some unmeasured specimens.

Stratigraphical units: Schellenbrücke Bed and Terrain à Chailles Member.

Age: The stratigraphical situation is the same as with *Perisphinctes (Otosphinctes) patuwattensis* (see above). The age is then the *cordatum* Subchron.

Perisphinctes (Otosphinctes) gresslyi DE LORIO, 1896 [m]

Plate 14, Fig. 2, Text-fig. 21, Table 18

1896 *Perisphinctes Gresslyi* – DE LORIO, p. 27, pl. 4, figs. 2–4

1901 *Perisphinctes Gresslyi* – DE LORIO, p. 26

non 1938 *Perisphinctes (Dichotomosphinctes) gresslyi* – ARKELL, p. 94, pl. 18, figs. 8–11.

Lectotype: The types of DE LORIO (1896) could not be found. They are neither in the ETH Zürich, the Museum of Natural History Basel, the Museum of Natural History Bern, the Muséum d'Histoire Naturelle Genève nor in the Musée Jurassien des sciences naturelles Porrentruy. DE LORIO (1901, p. 27) stated that the type of the taxon was from Châtillon. This is the original of DE LORIO (1896, pl. 4, fig. 2). This figure is then the lectotype as designated here. Since no topotypes are available, the selection of a neotype is deferred.

Type locality: Châtillon JU.

Type horizon: DE LORIO (1896, p. 28) did not indicate from which unit his types were. It can be concluded from the title of his paper that they are from the Terrain à Chailles Member.

Description: The iron oolitic, carbonate internal mould of specimen MNHB J 23345 from Üken is septate to the diameter of 43 mm. About one third of the last whorl is occupied by the body chamber. The last septal suture lines are not approximated. It is then possible that the specimen is immature. The whorl section is rounded and depressed. The primary ribs begin at the umbilical suture line. They are straight and almost radial on the inner whorls. On the body chamber they swing back on the rounded umbilical wall and lean 10° forward on the whorl sides. The primary ribs are high and sharp. They split into two secondary ribs at 72 % of the whorl height. The secondaries are fine and blunt. They have the same direction as the primary ribs and are not attenuated along the siphuncle. The last whorl covers the preceding one by about 50 %. There are two deep constrictions per whorl. Three of the primary ribs on the body chamber are irregular: they split into secondaries at a lower whorl height than normal.

Affinities: The description of the taxon by DE LORIO (1896, 1901) agrees well with the specimen described here. However, no parabolic nodes can be seen on MNHB J 23345. The ribbing of the specimens as figured by ARKELL (1938, pl. 18, figs. 2–4) is looser than in MNHB J 23345.

Material: 1 specimen, MNHB J 23345.

Stratigraphical unit: Schellenbrücke Bed.

Age: The specimen from Üken has a minimum age of the *cordatum* Chron (GYGI & MARCHAND, 1982). ARKELL's specimens are from the Elsworth Rock and have therefore a younger age, the *plicatilis* Chron. The lectotype of DE LORIO (1896) is from the Terrain à Chailles Member, so it cannot be older than the *cordatum* Subchron. Therefore the vertical range of *Perisphinctes (Otosphinctes) gresslyi* DE LORIO is probably restricted to the *cordatum* Subzone.

Ribs per whorl

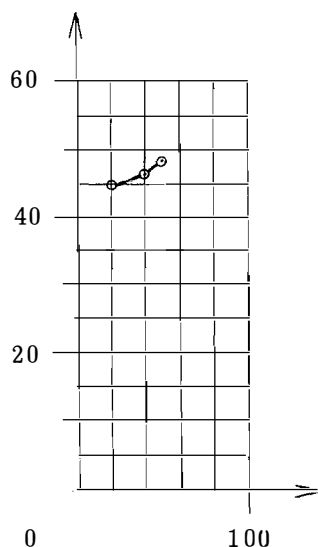

Diameter in mm Text-fig. 21. Rib curve of *Perisphinctes (Otosphinctes) gresslyi* DE LORIO, J 23345.

Table 18. Dimensions of *Perisphinctes (Otosphinctes) gresslyi* DE LORIOI [m].

Individual labelling of specimen	Ph mm	Dimensions, mm				in % of Dm			Ur/whorl	
		Dm	Wh	Wt	Um	Wh	Wt	Um	Dm	n
MNHB J 23345	43	50.5	16.0	20.0	23.1	32	40	46	50 40 20	48 47 45

Perisphinctes (Otosphinctes) cf. ouatius BUCKMAN, 1926 [m]

Plate 11, Fig. 2, Text-fig. 22, Table 19

Description: The iron oolitic, carbonate internal mould is septate to the diameter of 39 mm. Half the last whorl is occupied by the body chamber. The whorl section is ellipsoidal. The whorl height is greater than the whorl thickness (Table 19). The primary ribs begin near the umbilical suture line. They are straight, sharp and nearly radial. The position of the point of division into secondary ribs varies between 48% and 70% of the whorl height. The secondary ribs are strong. They have a slight forward inclination and form a proconcave arc on the siphonal side. The secondaries are interrupted along a siphonal furrow on the last fourth whorl of the phragmocone.

Affinities: The figured specimen resembles in its size and ribbing *Otosphinctes ouatius* BUCKMAN, 1926, but the following differences show that it is not conspecific with BUCKMAN's taxon. The whorl section of MNHB J 23248 is higher than wide, whereas it is, according to ARKELL (1936, p. xlv) depressed to rounded-quadrate in the English taxon. There is no forward sweep of the secondary ribs in *O. ouatius* BUCKMAN as can be observed in the Swiss specimen. The latter has a narrower umbilicus and a lesser whorl thickness than BUCKMAN's taxon (Table 19).

Material: 1 specimen, MNHB J 23248.

Stratigraphical unit: Schellenbrücke Bed.

Age: Probably *cordatum* Subchron.

Perisphinctes (Otosphinctes) zbindeni n. sp. [m]

Plate 2, Fig. 5, Plate 10, Fig. 2, Text-fig. 23, Table 20

Holotype: Plate 2, Fig. 5, MNHB J 23406.

Type locality: Excavation RG 208 on Brunnrain, Üken AG.

Type horizon: Schellenbrücke Bed, early Oxfordian, no. 8 of the excavation.

Ribs per whorl

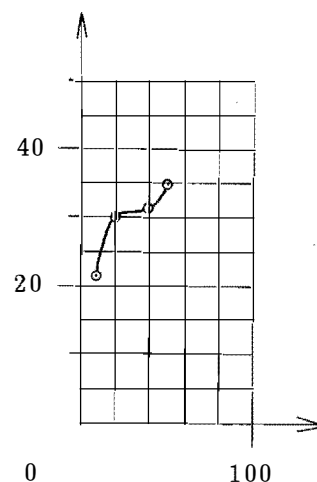

Text-fig. 22. Rib curve of *Perisphinctes (Otosphinctes) cf. ouatius* BUCKMAN J 23248.

Diameter in mm

Table 19. Dimensions of *Perisphinctes (Otosphinctes) cf. ouatius* BUCKMAN [m].

Individual labelling of specimen	Ph mm	Dimensions, mm				in % of Dm			Ur/whorl	
		Dm	Wh	Wt	Um	Wh	Wt	Um	Dm	n
MNHB J 23248	39	51.4	17.0	14.5	21.4	33	28	42	51 40 20 10	35 32 30 22

Derivation of the name: The name honours the couple H. & A. Zbinden, Ipsach BE, private collectors who gave many important ammonites to the Museum of Natural History Basel.

Diagnosis: Microconchs of *Perisphinctes* with a maximum diameter of 83 mm. The whorl section is thick-trapezoidal (depressed) with a rounded siphonal side. The ribbing is strong and dichotome.

Description: The iron oolitic, carbonate internal mould of the holotype is septate to the diameter of 49 mm. Seven eighths of the last whorl are occupied by the body chamber which is partly preserved to the last constriction before the peristome. Part of the body chamber and the peristome is broken off. The whorl section is depressed. The umbilical wall is rounded. The whorl sides are convex, and the siphonal side is rounded. The whorl sides are somewhat convergent. The primary ribs begin at the umbilical suture line. They are straight, strong and radial. It is only on the innermost visible whorl that they lean forward. The point of division into two secondary ribs is at between 76 % and 80 % of the whorl height. The strong secondary ribs bend forward and form a proconvex arc on the siphonal side. There are two to three deep constrictions per whorl. The last whorl covers the preceding one by about 20 %.

Affinities: *P. (O.) zbindeni* n.sp. resembles *Perisphinctes (Dichotomosphinctes) magnouatius* ARKELL. The two taxa have almost the same size and a similar type of ribbing, even though they have a different age. The inner whorls of the holotype of *Perisphinctes (Dichotomosphinctes) magnouatius* ARKELL are only partially visible. Moreover, the inner whorls of the paratype in ARKELL (1938, pl. 17, fig. 12) have less ribs than *Perisphinctes (Otosphinctes) zbindeni* n.sp. Therefore it appears to be advisable to keep the Swiss taxon separate from the English one. The age of *Perisphinctes (Otosphinctes) magnouatius* ARKELL is probably the *antecedens* Subchron (ARKELL, 1938, p. 94 and 1925–27, fig. 7).

Ribs per whorl

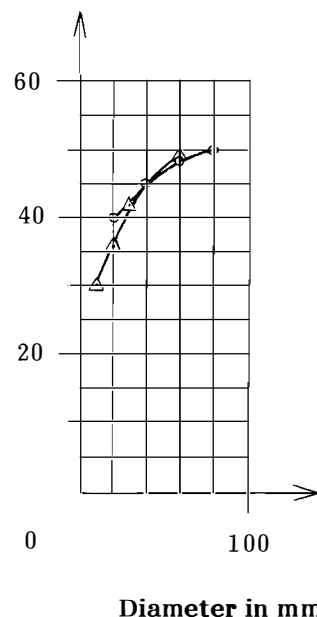

Text-fig. 23. Rib curves of *Perisphinctes (Otosphinctes) zbindeni* n.sp. Circles: holotype J 23406, triangles: J 23203.

Table 20. Dimensions of *Perisphinctes (Otosphinctes) zbindeni* n. sp. [m].

Individual labelling of specimen	Ph mm	Dimensions, mm				in % of Dm			Ur/whorl	
		Dm	Wh	Wt	Um	Wh	Wt	Um	Dm	n
MNHB J 23406 Holotype	49	82.7	22.4	23.7	43	27	29	52	80	50
									60	48
									40	45
									20	40
MNHB J 23203	46	59.3	18.8	21.0	27.0	32	35	46	60	49
									40	49
									30	42
									20	36
									10	30

Material: 2 specimens, MNHB J 23406 and J 23203.

Stratigraphical unit: Schellenbrücke Bed.

Age: The minimum age is the *cordatum* Subchron.

Subgenus indeterminatum

Perisphinctes (subg. indet.) sp.

Plate 8, Fig. 4, Text-fig. 24, Table 21

Description: The iron oolitic, carbonate internal mould is a wholly septate nucleus. The whorl section is thick-oval. On the inner whorls the primary ribs begin at the umbilical suture line. On the last whorl they begin higher up, and the lowest part of the umbilical wall is smooth. The strong primary ribs swing back on the umbilical margin and then forward on the whorl sides. Their forward inclination is 10° on the inner whorls and 5° on the last whorl. The point of division into two and occasionally three secondary ribs is at 70 % of the whorl height. The secondary ribs are weak and blunt and have the same direction as the primaries. They are interrupted along a narrow siphonal band. The rib curve (Text-fig. 24) is characteristic: It first descends from 43 ribs at the diameter of 20 mm to 40 ribs at the diameter of 50 mm, then rises again.

Ribs per whorl

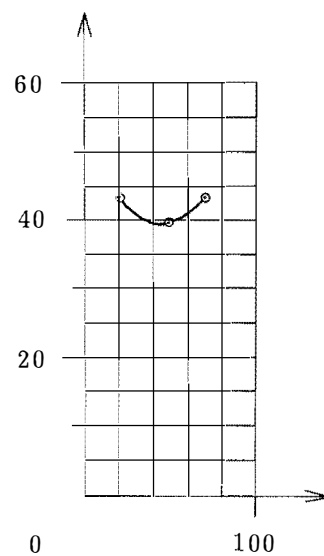

Text-fig. 24. Rib curve of *Perisphinctes* (subgenus indet.) sp.

Diameter in mm

Table 21. Dimensions of *Perisphinctes* (subgenus indet.) sp.

Individual labelling of specimen	Ph mm	Dimensions, mm				in % of Dm			Ur/whorl	
		Dm	Wh	Wt	Um	Wh	Wt	Um	Dm	n
MNHB J 23225	Nu	70	22	-	32	31	-	46	70 50 20	43 40 43

Affinities: All the measurable characters are similar to *Dichotomoceras* of the *bifurcatus* Chron. But the known *Dichotomoceras* first appear only in the *rotoides* Subchron. There is a time gap of four subchrons between the specimen described here and the oldest known *Dichotomoceras*. It is therefore unlikely that MNHB J 23225 is a direct precursor of *Dichotomoceras*, and its systematic position must remain uncertain.

Material: MNHB J 23225.

Stratigraphical unit: Schellenbrücke Bed.

Age: The minimum age is the *cordatum* Subchron.

Genus Subdiscosphinctes MALINOWSKA, 1972

Subgenus Subdiscosphinctes MALINOWSKA, 1972 [m]

Type species: *Perisphinctes kreutzii* SIEMIRADZKI, 1891 [m]

Subdiscosphinctes (Subdiscosphinctes)? sp. [m]

Plate 10, Fig. 4, Text-fig. 25, Table 22

Description: The iron oolitic, carbonate internal mould is septate to the diameter of 34 mm. The body chamber is complete to the last constriction before the peristome and occupies two thirds of the last whorl. The lappets of the peristome are mostly broken off. The whorl section is oval. The primary ribs begin at the umbilical suture line. They swing backward on the rounded umbilical wall, then bend 10° forward on the whorl sides of the body chamber. On the inner whorls the forward inclination of the straight primary ribs can be more than 20°.

Ribs per whorl

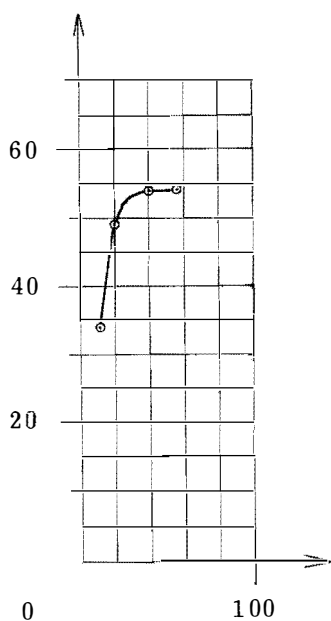

Diameter in mm

Text-fig. 25. Rib curve of *Subdiscosphinctes (Subdiscosphinctes)?* sp.

Table 22. Dimensions of *Subdiscosphinctes* (*Subdiscosphinctes*)? sp. [m].

Individual labelling of specimen	Ph mm	Dimensions, mm				in % of Dm			Ur/whorl	
		Dm	Wh	Wt	Um	Wh	Wt	Um	Dm	n
ETH Zürich	34	56	19	17	22	34	29	39	56 40 20 10	54 54 49 34

The primary ribs split into two secondaries at 75% of the whorl height. The fine secondary ribs have the same direction as the primaries and are not attenuated at the siphonal side. There is only one constriction which is at the beginning of the body chamber. The last whorl covers the preceding one by about a third.

Affinities: The figured specimen might be assigned to *Alligaticeras*, *Prososphinctes*, *Perisphinctes* (*Otosphinctes*) or *Subdiscosphinctes* (*Subdiscosphinctes*). It is unlikely that the specimen from Herznach belongs to *Alligaticeras*, because its umbilicus is too narrow and because the whorl section is not quadrate. *Prososphinctes* can be ruled out, since the ribbing on the last whorl of the Herznach specimen is not as pronouncedly prorsiradiate as in the type species of *Prososphinctes* (see BUKOWSKI, 1887, pl. 6, fig. 8). The specimen as figured here has a whorl section which is not as high as in *Prososphinctes*, and there are not as many constrictions as in the Polish taxon. The umbilicus of the Herznach specimen is too narrow and the ribbing on the inner whorls is too dense for an assignment to *Perisphinctes* (*Otosphinctes*). However, the ribbing on the inner whorls, the umbilicus and the whorl section compare with *Subdiscosphinctes* (*Subdiscosphinctes*). But the rib curve of the Herznach specimen flattens out at the diameter of 40 mm, whereas the curve of typical *Subdiscosphinctes* (*Subdiscosphinctes*) rises to the aperture. This is why the specimen figured here is assigned with a question mark to *Subdiscosphinctes* (*Subdiscosphinctes*). Another reason is that known *Subdiscosphinctes* first appear only in the late *antecedens* Subchron, whereas the minimum age of the specimen from Herznach is the *cordatum* Subchron.

Material: 1 specimen ETH Zürich, without number.
Stratigraphical unit: Schellenbrücke Bed.
Age: The minimum age is the *cordatum* Subchron.

3. Conclusions

The described perisphinctid ammonite fauna contains forms that are grouped into a new genus and a new subgenus which are thought to be a dimorphic pair. 8 new formal and two new informal taxa at the species level have been recognized. The exact age (subchron) of some previously described species is indicated here for the first time.

Specimens with a minimum age of the *cordatum* Subchron resembling microconchs of much younger *Subdiscosphinctes* and *Perisphinctes* (*Dichotomoceras*) occur in the Schellenbrücke Bed.

Acknowledgements

A large part of the figured ammonites has been excavated and prepared by Sylvia Gygi. She also typed the text and the tables and drew most of the figures in ink. S. Dahint of the Museum of Natural History Basel made the photographs. R. Eichen (Zürich) and G. Schmid (Zofingen) gave ammonites as a present to the Museum of Natural History Basel. M. Pika-Biolzi at the Geological Institute of the ETH Zürich gave ammonites from Herznach on loan. The permission to measure Neumann's types at the University of Vienna was given by L. Krystyn. H. Gauthier (Paris) helped with work in the collections of the Musée d'Histoire Naturelle and of the Université de Paris. The inspection of the collections in the University Museum at Oxford was made possible by W.J. Kennedy. D. Marchand (Dijon) showed the collection of M. Collignon in the Geological Institute of the Université de Bourgogne. The author is grateful to J. Callomon who carefully read the manuscript and made many suggestions for improvements.

References

- ARKELL, W.J. (1925–27): The Corallian rocks of Oxford, Berks and North Wilts. – Phil. Trans. roy. Soc. London, (B), 216: 67–181, London.
- (1935–48): A monograph of the ammonites of the English Corallian beds. – Monogr. palaeontograph. Soc. (London), London.
- BOURSEAU, J.-P. (1977): L'Oxfordien moyen à nodules des "Terres Noires" de Beauvoisin (Drôme). – Nouv. Arch. Mus. Hist. nat. Lyon, 15: 1–116, Lyon.
- BROCHWICZ-LEWINSKI, W. (1975): On the Oxfordian genus *Subdiscosphinctes* MALINOWSKA, 1972, and subgenus *Aureimontanites* nov. (Perisphinctidae, Ammonoidea). – Acta palaeont. pol., 20, 1: 87–96, Warszawa.
- (1976): Some difficulties in recognition of sexual dimorphism in Jurassic perisphinctids. – Acta palaeont. pol., 21, 1: 115–125, Warszawa.
- BUCKMAN, S. S. (1909–30): Type ammonites. Vols. 1–7, 1909–1928. Indexes by A. MORLEY DAVIES, 1930. 790 pl., London (Wheldon & Wesley).
- BUKOWSKI, G. (1887): Ueber die Jurabildungen von Czenstochau in Polen. – Beitr. Paläont. Österr.-Ungarns u. d. Orients, 5: 75–171, Wien.
- CALLOMON, J. H. (1963): Sexual dimorphism in Jurassic ammonites. – Transact. Leicester lit. philosoph. Soc., 58: 21–56, Leicester.
- (1985): The evolution of the Jurassic ammonite family Cardioceratidae. – Palaeontology, Spec. Pap., 33: 49–90, London.
- CECCA, F. & ENAY, R. (1991): Les ammonites des zones à *semiforme* et à *fallauxi* du Tithonique de l'Ardèche (sud-est de la France): Stratigraphie, paléontologie, paléobiogéographie. – Palaeontographica (A), 219: 1–87, Stuttgart.
- COLINVAUX, P. (1978): Why big fierce animals are rare. – Princeton University Press, Princeton.
- COLLIGNON, M. (1959): Atlas des fossiles caractéristiques de Madagascar. Fascicule 3 (Oxfordien). – Service géologique, Tananarive.
- CRANE, J. (1941): Crabs of the genus *Uca* from the West coast of Central America. – Zoologica (New York zool. Soc.), 26: 145–208, New York.
- DORN, P. (1930): Die Ammonitenfauna des untersten Malm der Frankenalb. – Palaeontographica, 73: 107–172, Stuttgart.
- ENAY, R. (1966): L'Oxfordien dans la moitié sud du Jura français. – Nouv. Arch. Mus. Hist. nat. Lyon, 8: 1–624, Lyon.
- FISCHER, H. & GYGI, R. (1989): Numerical and biochronological time scales correlated at the ammonite subzone level; K–Ar, Rb–Sr ages, and Sr, Nd, and Pb sea-water isotopes in an Oxfordian (Late Jurassic) succession of northern Switzerland. – Geol. Soc. America Bull., 101: 1584–1597, Baltimore.
- GAUSE, G. F. (1934): The struggle for existence. – Williams and Wilkins, Baltimore.
- GYGI, R. (1975): *Sparisoma viride* (BONNATERRE), the Stoplight Parrotfish, a major sediment producer on coral reefs of Bermuda? – Eclogae geol. Helv., 68, 2: 327–359, Basel.
- (1977): Revision der Ammonitengattung *Gregoryceras* (Aspidoceratidae) aus dem Oxfordian (Oberer Jura) der Nordschweiz und von Süddeutschland. Taxonomie, Phylogenie, Stratigraphie. – Eclogae geol. Helv., 70, 2: 435–542, Basel.
- (1981): Oolitic iron formations: marine or not marine? – Eclogae geol. Helv., 74, 1: 233–254, Basel.
- (1995): Datierung von Seichtwassersedimenten des Späten Jura in der Nordwestschweiz mit Ammoniten. – Eclogae geol. Helv., 88, 1: 1–58, Basel.
- (In press): Integrated stratigraphy of the Oxfordian and Kimmeridgian (Late Jurassic) in northern Switzerland and adjacent southern Germany. – Denkschr. schweiz. natf. Ges., 104.
- GYGI, R. & MARCHAND, D. (1982): Les faunes de Cardioceratinae (Ammonoidea) du Callovien terminal et de l'Oxfordien inférieur et moyen (Jurassique) de la Suisse septentrionale: Stratigraphie, paléoécologie, taxonomie préliminaire. – Geobios, 15, 4: 517–571, Lyon.
- JEANNET, A. (1951): Stratigraphie und Palaeontologie des oolithischen Eisenerzlagers von Herznach und seiner Umgebung. I. Teil. – Beitr. Geol. Schweiz, geotech. Ser., 13, 5: 1–240, Bern.
- LORIOU, P. DE (1896): L'Oxfordien supérieur et moyen du Jura bernois. Première partie. – Mém. Soc. paléont. suisse, 23: 1–77, Genève.
- (1897): L'Oxfordien supérieur et moyen du Jura bernois. Seconde partie. – Mém. Soc. paléont. suisse, 24: 78–159, Genève.
- (1901): L'Oxfordien supérieur et moyen du Jura bernois. Premier supplément. – Mém. Soc. paléont. suisse, 28: 1–119, Genève.
- MALINOWSKA, L. (1972): The middle Oxfordian Perisphinctidae of Zawodzie near Czestochowa (Poland). – Acta palaeont. pol., 17, 2: 167–242, Warszawa.
- MANGOLD, C. (1970): Stratigraphie des étages Bathonien et Callovien du Jura méridional. – Doc. Lab. Géol. Fac. Sci. Lyon, 41, 1–2: 1–376, Lyon.
- MARCHAND, D. (1986): L'évolution des Cardioceratinae d'Europe occidentale dans leur contexte paléobiogéographique (Callovien supérieur – Oxfordien moyen). – Unpubl. Ph. D. thesis Univ. Bourgogne, Dijon.
- MAYR, E. (1964): Systematics and the origin of species from the viewpoint of a zoologist. – (Dover), New York.
- (1975): Grundlagen der zoologischen Systematik. – (Parey), Hamburg.
- MELLENDEZ, G. (1989): El Oxfordiense en el sector central de la Cordillera Iberica (Provincias de Zaragoza y Teruel). – Institucion Fernando el catolico, Zaragoza.
- NEUMANN, J. (1907): Die Oxfordfauna von Cetechowitz. – Beitr. Paläont. (Geol.) Österr.-Ungarn u. Orient, 20: 1–67, Wien.
- SPATH, L. F. (1931): Revision of the Jurassic cephalopod fauna of Kachh (Cutch), parts 4–5. – Palaeontologia Indica, N. S., 9, 2: 279–658, Calcutta.
- (1938): A catalogue of the ammonites of the Liassic family Liparoceratidae in the British Museum (Natural History). – (British Museum), London.
- TINTANT, H. (1961): Etudes sur les ammonites de l'Oxfordien supérieur de Bourgogne. I. – Les genres *Platysphinctes* nov. et *Larcheria* nov. – Bull. sci. Bourgogne, 19, (1958–1959): 109–144, Dijon.
- WAAGEN, W. (1873–75): Jurassic fauna of Kutch. The Cephalopoda. – Palaeontologia Indica, 1: 1–247, Calcutta.

- ZEISS, A. (1955): Zur Stratigraphie des Callovien und Unter-Oxfordien bei Blumberg (Südbaden). – Jh. geol. Landesamt Baden-Württemberg, 1: 239–266, Freiburg i. Br.
- (1969): Dimorphismus bei Ammoniten des Unter-Tithon. – In: WESTERMANN, G. E. G. (ed.): Sexual dimorphism in fossil Metazoa and taxonomic implications. Int. Un. geol. Sci., (A), 1, (Schweizerbart), Stuttgart, pp. 155–164.

Explanation of plates

An arrow indicates the position of the last septum, if this can be ascertained.

Plate 1

- Fig. 1. *Tenuisphinctes (Tenuisphinctes) kruegeri* n. g., n. sp. [M], holotype. Out of a rock fallen from the Schellenbrücke Bed, locality RG 251, iron mine, Herznach AG. J 27523, leg. WABH, × 1.

Plate 2

- Fig. 1. *Perisphinctes (Otosphinctes) episcopalis* DE LORIOLE [m]. From *cordatum* Zone, *cordatum* Subzone, Schellenbrücke Bed, excavation RG 208, bed 8, Brunnenrain, Üken AG. J 23328, leg. R. & S. Gygi, × 1.
- Fig. 2. *Perisphinctes (Otosphinctes) episcopalis* DE LORIOLE [m]. From *cordatum* Zone, *cordatum* Subzone, Schellenbrücke Bed, excavation RG 208, bed 9, Brunnenrain, Üken AG. J 23287, leg. R. & S. Gygi, × 1.
- Fig. 3. *Tenuisphinctes (Tenuisphinctes) kruegeri* n. g., n. sp. [M]. Schellenbrücke Bed, iron mine, Herznach AG. Collection L. Rollier at ETHZ without number, × 1.
- Fig. 4. *Perisphinctes (Arisphinctes)* sp. gr. *plicatilis* (SOWERBY) [M]. From *cordatum* Zone, *cordatum* Subzone, Schellenbrücke Bed, locality RG 93, bed 4, iron mine, Herznach AG. J 32298, leg. R. Gygi, × 1.
- Fig. 5. *Perisphinctes (Otosphinctes) zbindeni* n. sp. [m], holotype. Upper Herznach Formation, excavation RG 208, bed 7b, Brunnenrain, Üken AG. J 23406, leg. R. & S. Gygi, × 1.

Plate 3

- Fig. 1. *Perisphinctes (Arisphinctes) healeyi* NEUMANN [M]. Probably *cordatum* Zone, *cordatum* Subzone, Schellenbrücke Bed, iron mine, Herznach AG. J 30513, don. G. Schmid, × 0.9.

Plate 4

- Fig. 1. *Perisphinctes (Arisphinctes) primigenius* n. sp. [M]. Schellenbrücke Bed, excavation RG 208, bed 9, Brunnenrain, Üken AG. J 23232, leg. R. & S. Gygi, × 1.

Plate 5

- Fig. 1. *Perisphinctes (Arisphinctes) iodes* n. sp. [M]. Schellenbrücke Bed, section RG 209, bed 7, iron mine, Strecke IV, Herznach AG. J 23414, leg. R. Gygi, × 1.

Plate 6

- Fig. 1. *Perisphinctes (Arisphinctes)* sp. A, [M]. Out of rock fallen from the Schellenbrücke Bed, iron mine, Herznach AG. J 23457, leg. et don. R. Eichin, × 1.

Plate 7

- Fig. 1. *Perisphinctes (Arisphinctes)* sp. B, [M]. Out of rock fallen from the Schellenbrücke Bed, locality RG 261, iron mine, Herznach AG. J 27566, leg. WABH, × 0.9.
- Fig. 2. *Perisphinctes (Otosphinctes) episcopalis* DE LORIOLE [m]. From *cordatum* Zone, *cordatum* Subzone. Out of rock fallen from the Schellenbrücke Bed, iron mine, Herznach AG. J 23468, leg. et don. R. Eichin, × 1.
- Fig. 3. *Perisphinctes (Otosphinctes) episcopalis* DE LORIOLE [m]. From *cordatum* Zone, *cordatum* Subzone. Out of rock fallen from the Schellenbrücke Bed, locality RG 251, iron mine, Herznach AG. J 27530, leg. WABH, × 1.

Plate 8

- Fig. 1. *Perisphinctes (Arisphinctes) cf. healeyi* NEUMANN [M]. Out of rock fallen from the Schellenbrücke Bed, locality RG 251, iron mine, Herznach AG. J 27531, leg. WABH, × 1.
- Fig. 2. *Perisphinctes (Otosphinctes) paturattensis* DE LORIOLO [m]. From *cordatum* Zone, *cordatum* Subzone. Out of rock fallen from the Schellenbrücke Bed, locality RG 244, iron mine, Herznach AG. J 27420, leg. WABH, × 1.
- Fig. 3. *Perisphinctes (Otosphinctes) paturattensis* DE LORIOLO [m]. From *cordatum* Zone, *cordatum* Subzone, Schellenbrücke Bed, excavation RG 208, bed 9, Brunnrain, Üken AG. J 23290, leg. R. & S. Gygi, × 1.
- Fig. 4. *Perisphinctes* (subgenus indet.) sp. Schellenbrücke Bed, excavation RG 208, beds 8–9, Brunnrain, Üken AG. J 23225, leg. R. & S. Gygi, × 1.
- Fig. 5. *Perisphinctes (Arisphinctes) parvus* n.sp. [M], holotype. From *cordatum* Zone, *cordatum* Subzone, Glaukonitsandmergel Bed, excavation RG 212, bed 5, above shooting range, Churz Tal, Siblingen SH. J 24869, leg. R. & S. Gygi, × 1.

Plate 9

- Fig. 1. *Perisphinctes (Arisphinctes) parvus* n.sp. [M]. From *cordatum* Zone, *cordatum* Subzone, Schellenbrücke Bed, excavation RG 208, bed 9, Brunnrain, Üken AG. J 23249, leg. R. & S. Gygi, × 1.
- Fig. 2. *Tenuisphinctes (Eichinicerias) cf. rolandi* n.sp. [m]. Schellenbrücke Bed, section RG 245, bed 18, iron mine, Herznach AG. J 27464, leg. WABH, × 1.
- Fig. 3. *Perisphinctes (Eichinicerias) rolandi* n.sp. [m]. Schellenbrücke Bed, excavation RG 208, bed 8, Brunnrain, Üken AG. J 23339, leg. R. & S. Gygi, × 1.
- Fig. 4. *Perisphinctes (Arisphinctes) plicatilis* (SOWERBY) [M]. From *cordatum* Zone, *cordatum* Subzone, Schellenbrücke Bed, section RG 209, bed 9, iron mine, Herznach AG. J 23412, leg. R. Gygi, × 1.

Plate 10

- Fig. 1. *Perisphinctes (Kranaosphinctes) aff. cyrilli* NEUMANN [M]. Probably *cordatum* Zone, *cordatum* Subzone. Out of rock fallen from the Schellenbrücke Bed, locality RG 251, iron mine, Herznach AG. J 27520, leg. WABH, × 1.
- Fig. 2. *Perisphinctes (Otosphinctes) zbindeni* n.sp. [m]. Schellenbrücke Bed, excavation RG 208, beds 8–9, Brunnrain, Üken AG. J 23203, leg. R. & S. Gygi, × 1.
- Fig. 3. *Perisphinctes (Otosphinctes) paturattensis* DE LORIOLO [m]. From *cordatum* Zone, *cordatum* Subzone, Schellenbrücke Bed, excavation RG 208, beds 8–9, Brunnrain, Üken AG. J 23224, leg. R. & S. Gygi, × 1.
- Fig. 4. *Subdiscosphinctes (Subdiscosphinctes)?* sp. [m]. Schellenbrücke Bed, F 3, iron mine, Herznach AG. ETHZ, without number, × 1.

Plate 11

- Fig. 1. *Perisphinctes (Kranaosphinctes) sylviae* n.sp. [M], holotype. Schellenbrücke Bed, excavation RG 208, beds 8–9, Brunnrain, Üken AG. J 23233, leg. R. & S. Gygi, × 1.
- Fig. 2. *Perisphinctes (Otosphinctes) cf. ouatius* BUCKMAN [m]. Schellenbrücke Bed, excavation RG 208, bed 9, Brunnrain, Üken AG. J 23248, leg. R. & S. Gygi, × 1.
- Fig. 3. *Perisphinctes (Otosphinctes) paturattensis* DE LORIOLO [m]. From *cordatum* Zone, *cordatum* Subzone, Schellenbrücke Bed, section RG 209, bed 7, iron mine, Herznach AG. J 23422, leg. R. Gygi, × 1.
- Fig. 4. *Tenuisphinctes (Eichinicerias) rolandi* n.sp. [m], holotype. Schellenbrücke Bed, iron mine, Herznach AG. J 22652, leg. B. Paganini, × 1.
- Fig. 5. *Perisphinctes (Arisphinctes) parvus* n.sp. [M]. Schellenbrücke Bed, iron mine, Herznach AG. J 23434, leg. et don. R. Eichin, × 1.

Plate 12

- Fig. 1. *Perisphinctes (Kranaosphinctes) sylviae* n.sp. [M]. Schellenbrücke Bed, excavation RG 208, beds 8–9, Brunnrain, Üken AG. J 23230, leg. R. & S. Gygi, × 1.
- Fig. 2. *Perisphinctes (Otosphinctes) paturattensis* DE LORIOLO [m]. From *cordatum* Zone, *cordatum* Subzone, Schellenbrücke Bed, excavation RG 208, bed 8, Brunnrain, Üken AG. J 23399, leg. R. & S. Gygi, × 1.
- Fig. 3. *Perisphinctes (Otosphinctes) paturattensis* DE LORIOLO [m]. From *cordatum* Zone, *cordatum* Subzone, Schellenbrücke Bed, excavation RG 208, bed 8, Brunnrain, Üken AG. J 23353, leg. R. & S. Gygi, × 1.
- Fig. 4. *Tenuisphinctes (Eichinicerias) rolandi* n.sp. [m]. Schellenbrücke Bed, iron mine, Herznach AG. J 23431, leg. et don. R. Eichin, × 1.
- Fig. 5. *Subdiscosphinctes? langei* n.sp. Schellenbrücke Bed, excavation RG 208, bed 9, Brunnrain, Üken AG. J 23251, leg. R. & S. Gygi, × 1.

Plate 13

- Fig. 1. *Tenuisphinctes* (*Tenuisphinctes*) sp. [M]. Schellenbrücke Bed, section RG 93, bed 4, iron mine, Herznach AG. J 32297, leg. R. Gygi, × 1.
- Fig. 2. *Perisphinctes* (*Otosphinctes*) *paturattensis* DE LORIOI [m]. From *cordatum* Zone, *cordatum* Subzone, Schellenbrücke Bed, excavation RG 208, beds 8–9, Brunnrain, Üken AG. J 23197, leg. R. & S. Gygi, × 1.
- Fig. 3. *Perisphinctes* (*Otosphinctes*) *paturattensis* DE LORIOI [m]. From *cordatum* Zone, *cordatum* Subzone, Schellenbrücke Bed, excavation RG 208, bed 8, Brunnrain, Üken AG. J 23317, leg. R. & S. Gygi, × 1.
- Fig. 4. *Perisphinctes* (*Kranasphinctes*) aff. *cyrilli* NEUMANN [M]. Schellenbrücke Bed, F 2, iron mine, Herznach AG. ETHZ 304, × 1.
- Fig. 5. *Subdiscosphinctes?* *langei* n. sp., holotype. From *cordatum* Zone, *cordatum* Subzone, top of Glaukonitsandmergel Bed, excavation RG 81 b, bed 12, below Räckolterenbuck, Gächlingen SH. J 24642, leg. R. & S. Gygi, × 1.

Plate 14

- Fig. 1. *Perisphinctes* (*Arisphinctes*) cf. *parvus* n. sp. Schellenbrücke Bed, iron mine, Herznach AG. J 23453, leg. et don. R. Eichin, × 1.
- Fig. 2. *Perisphinctes* (*Otosphinctes*) *gresslyi* DE LORIOI [m]. Schellenbrücke Bed, excavation RG 208, bed 8, Brunnrain, Üken AG. J 23345, leg. R. & S. Gygi, × 1.
- Fig. 3. *Perisphinctes* (*Otosphinctes*) *episcopalis* DE LORIOI [m]. From *cordatum* Zone, *cordatum* Subzone, Schellenbrücke Bed, excavation RG 208, bed 9, Brunnrain, Üken AG. J 23275, leg. R. & S. Gygi, × 1.
- Fig. 4. *Perisphinctes* (*Arisphinctes*) *plicatilis* (SOWERBY) [M]. From *cordatum* Zone, *cordatum* Subzone, Schellenbrücke Bed, excavation RG 208, beds 8–9, Brunnrain, Üken AG. J 23222, leg. R. & S. Gygi, × 1.
- Fig. 5. *Perisphinctes* (*Arisphinctes*) cf. *parvus* n. sp. Schellenbrücke Bed, excavation RG 208, bed 9, Brunnrain, Üken AG. J 23255, leg. R. & S. Gygi, × 1.



1

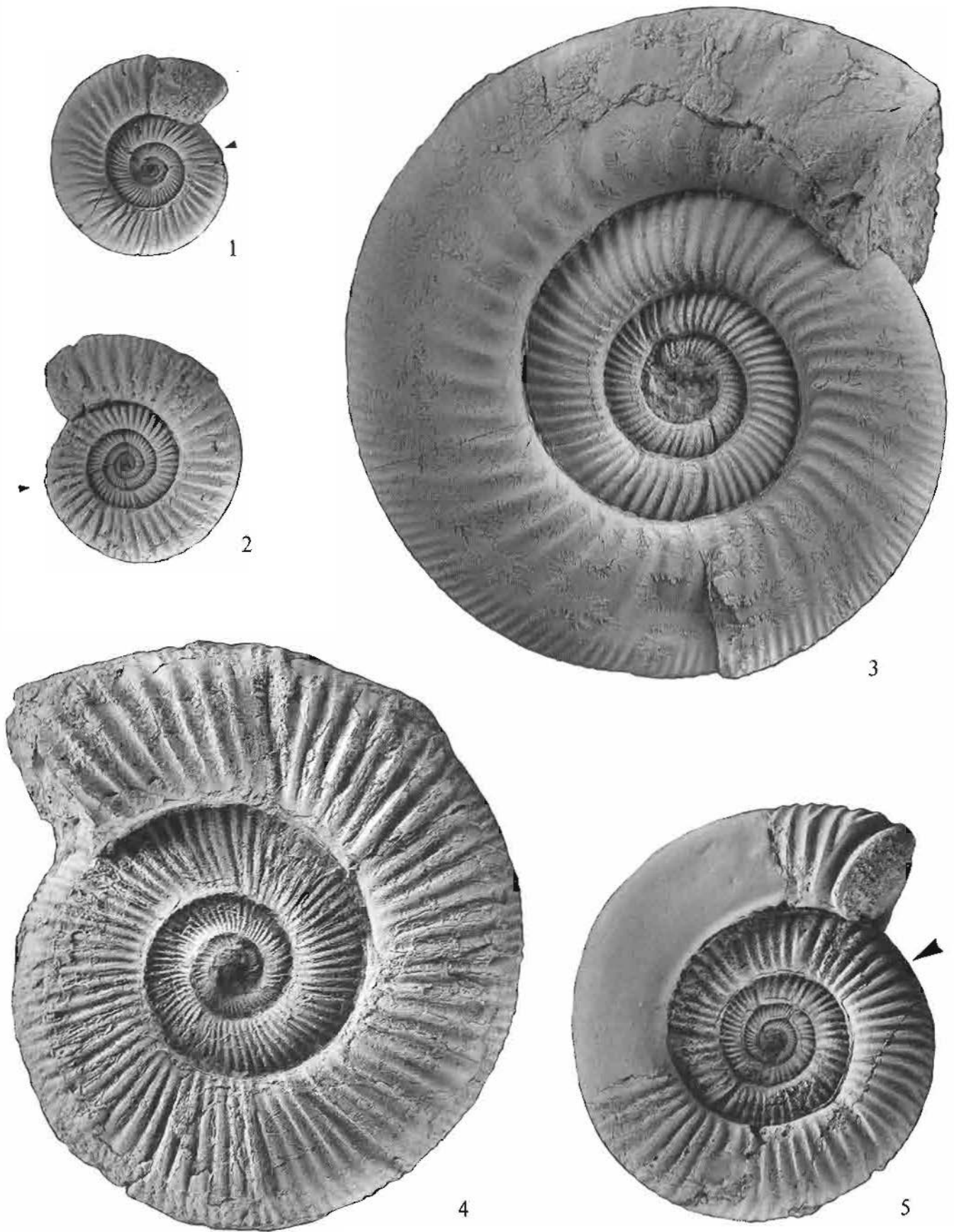

Reinhardt A. Gygi: Taxonomy of perispinctid ammonites of the Early Oxfordian.

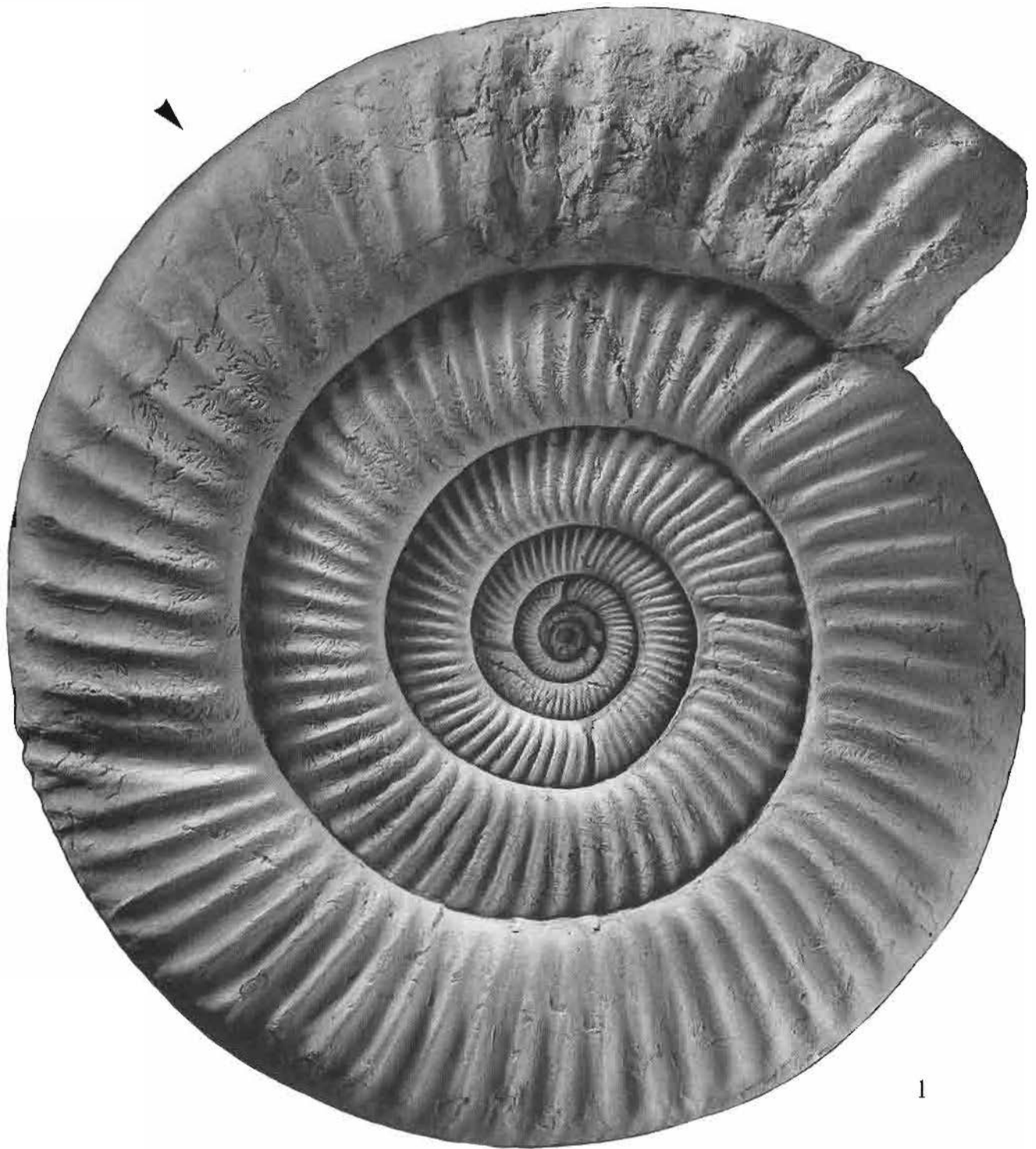



Reinhardt A. Gygi: Taxonomy of perisphinctid ammonites of the Early Oxfordian.



Reinhard A. Gygi: Taxonomy of perisphinctid ammonites of the Early Oxfordian.



1



Reinhart A. Gygi: Taxonomy of perisphinctid ammonites of the Early Oxfordian.

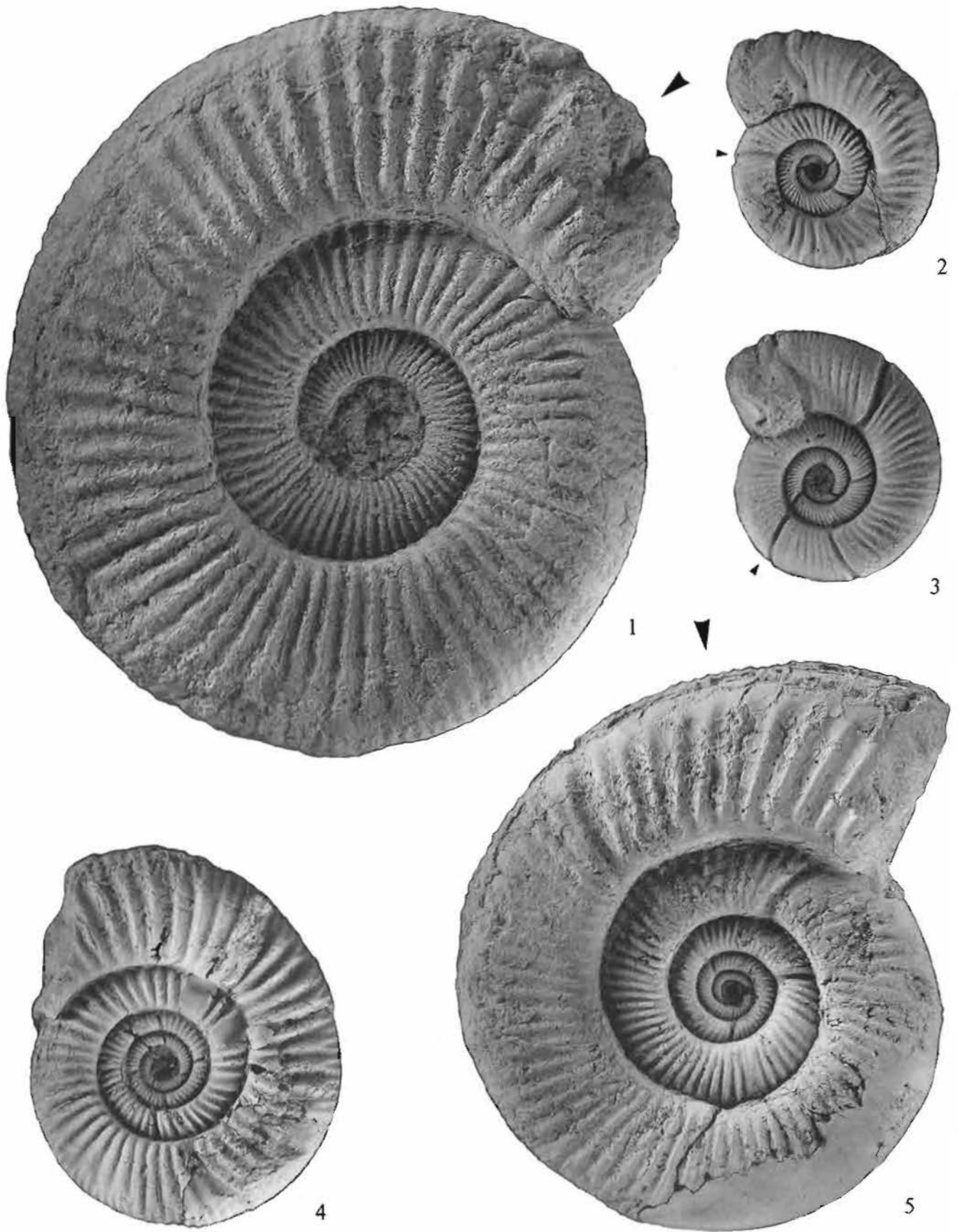

Reinhardt A. Gygi: Taxonomy of perisphinctid ammonites of the Early Oxfordian.

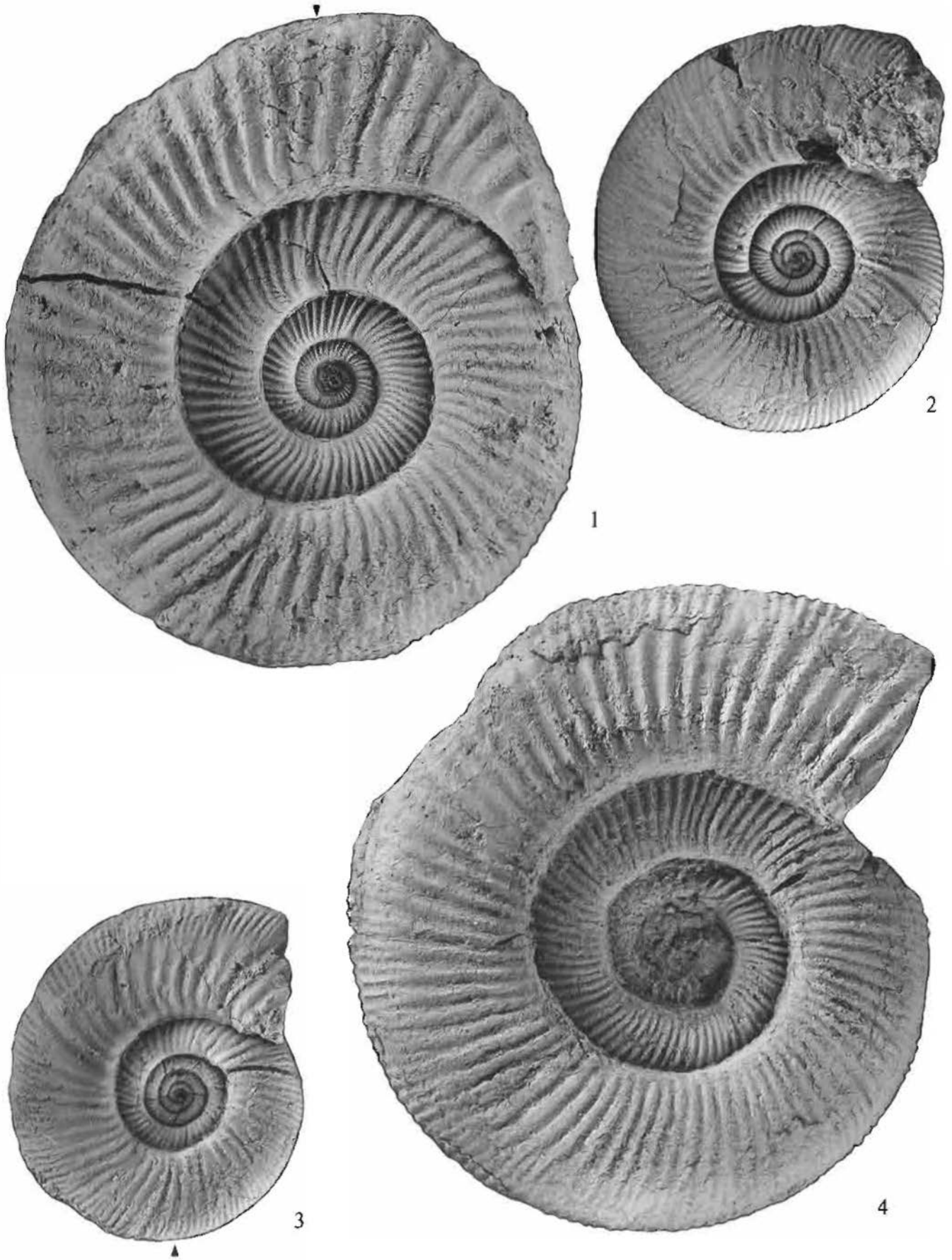

Reinhart A. Gygi: Taxonomy of perispinacid ammonites of the Early Oxfordian.

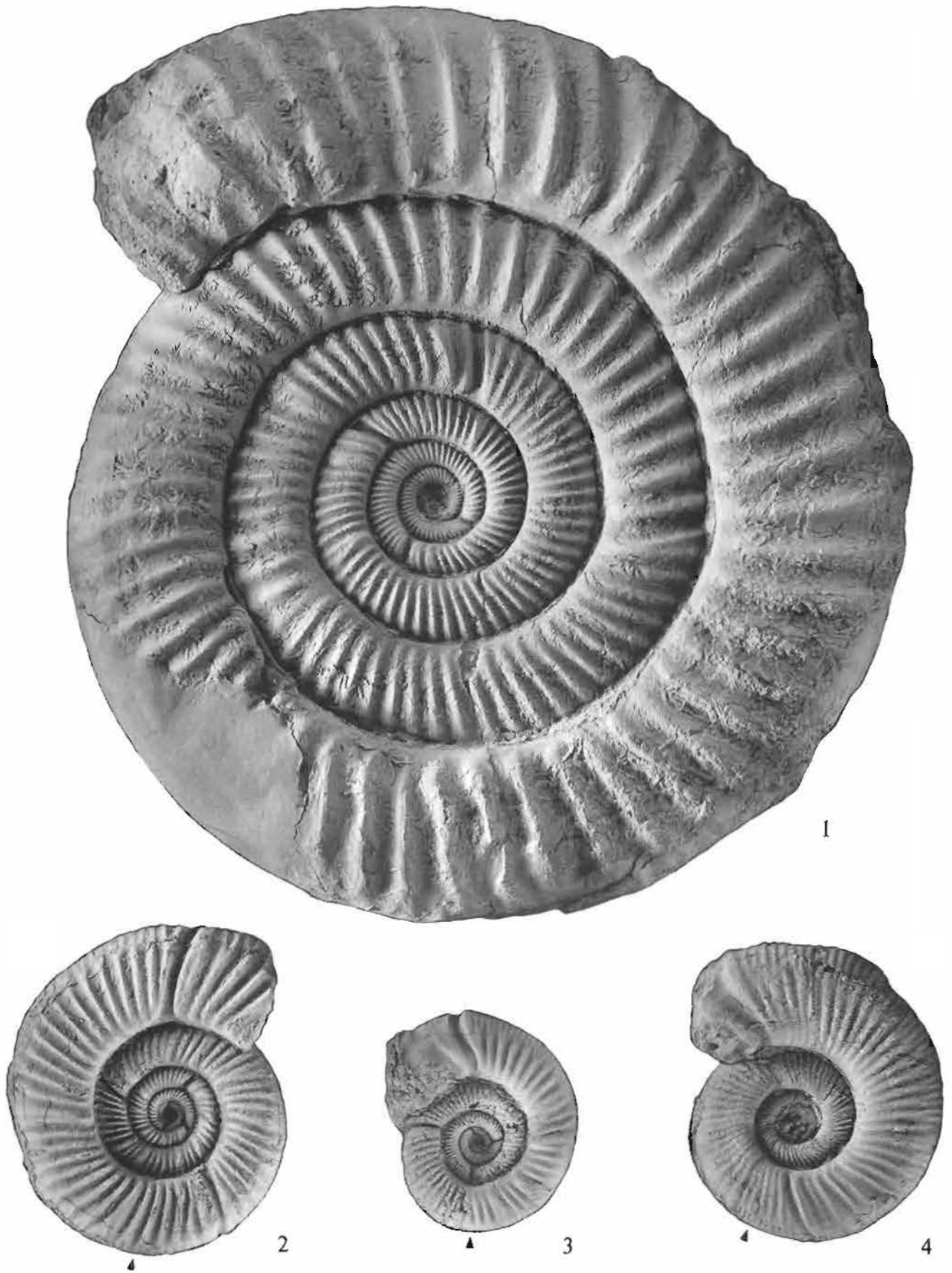

Reinhart A. Gygi: Taxonomy of perisphinctid ammonites of the Early Oxfordian.

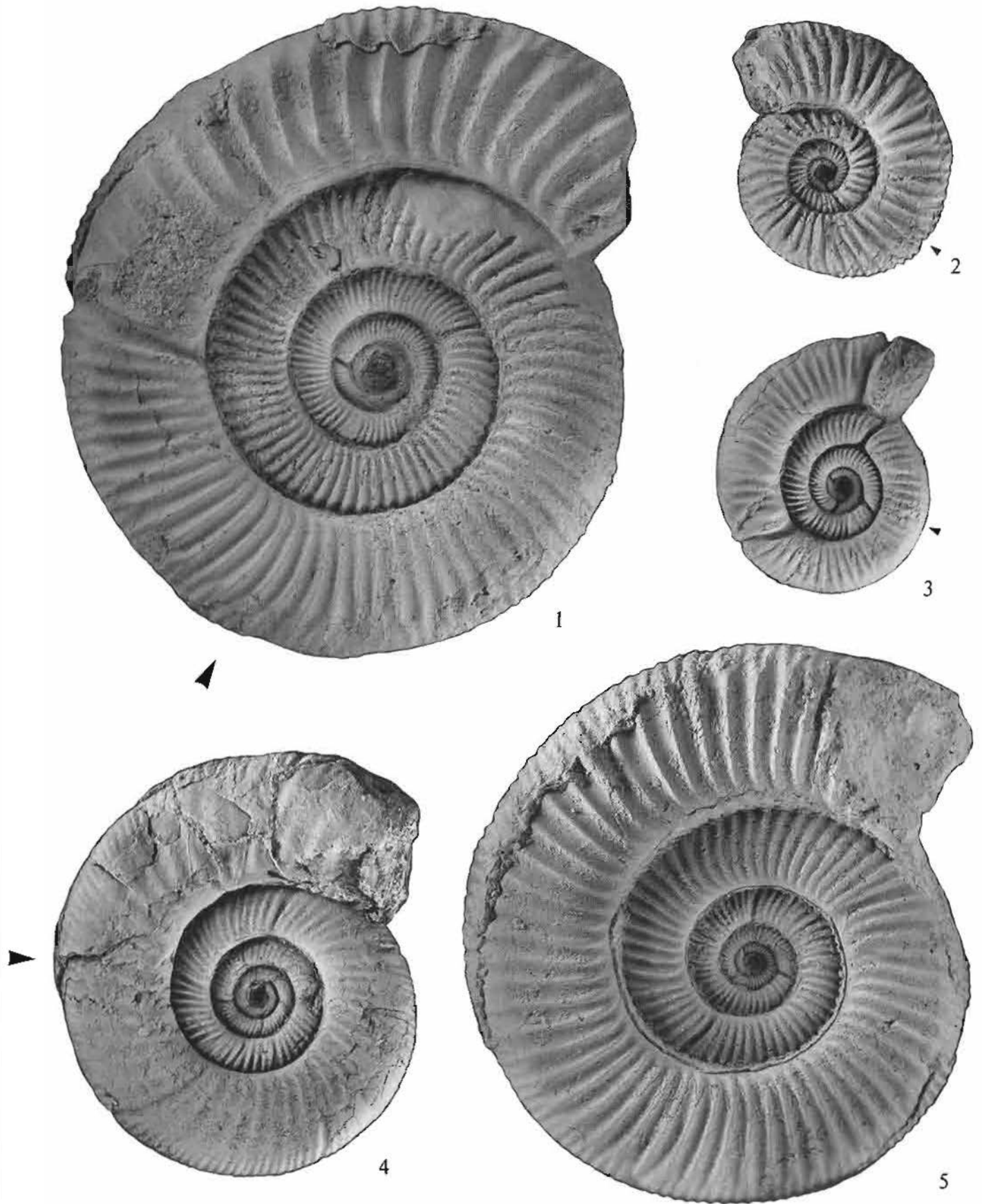

Reinhart A. Gygi: Taxonomy of perisphinctid ammonites of the Early Oxfordian.

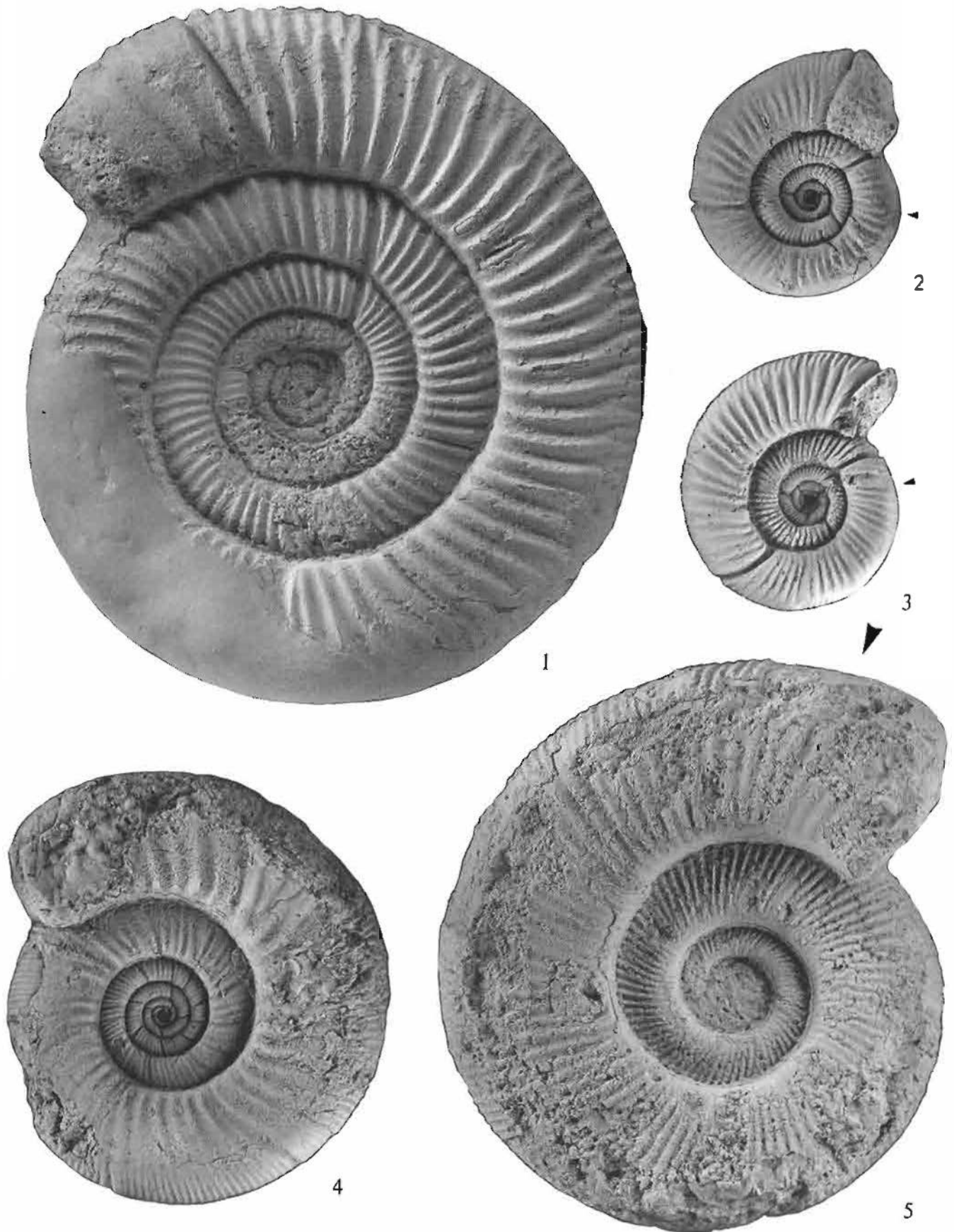

Reinhart A. Gygi: Taxonomy of perisphinctid ammonites of the Early Oxfordian.



Reinhard A. Gygi: Taxonomy of perisphinctid ammonites of the Early Oxfordian.

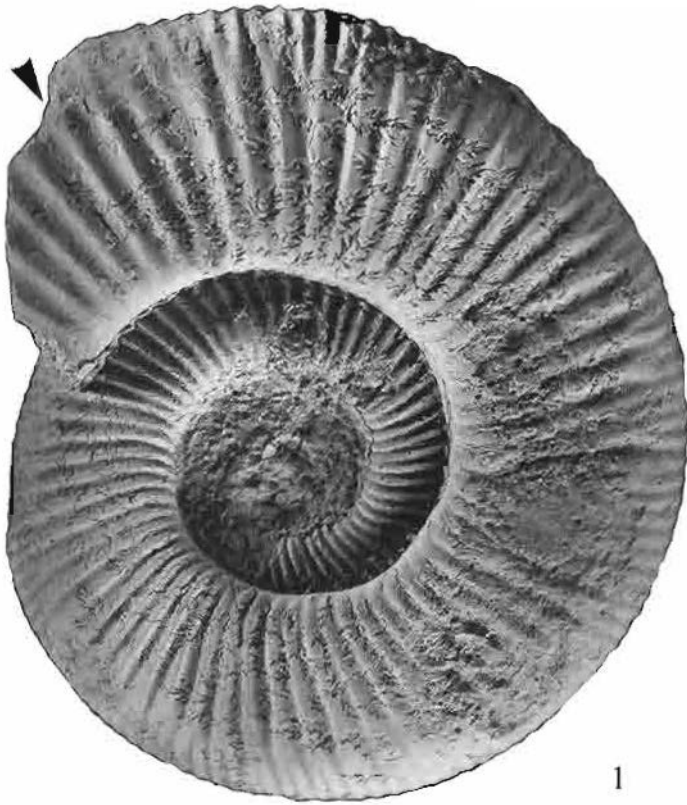

1



2



3



4



5